

Automatic generation control of TCPS based hydrothermal system under open market scenario: A fuzzy logic approach

C. Srinivasa Rao^{a,*}, S. Siva Nagaraju^b, P. Sangameswara Raju^c

^aEEE Department, G. Pulla Reddy Engineering College, Kurnool, Andhra Pradesh, India

^bEEE Department, J.N.T.U College of Engg., Kakinada, Andhra Pradesh, India

^cEEE Department, S.V. University, Tirupati, Andhra Pradesh, India

ARTICLE INFO

Article history:

Received 13 August 2007

Received in revised form 4 February 2009

Accepted 16 March 2009

Keywords:

AGC

Fuzzy logic controller

Open market system

TCPS

ABSTRACT

This paper presents the analysis of automatic generation control of a two-area interconnected thyristor controlled phase shifter based hydrothermal system in the continuous mode using fuzzy logic controller under open market scenario. Open transmission access and the evolving of more socialized companies for generation, transmission and distribution affects the formulation of AGC problem. So the traditional AGC two-area system is modified to take into account the effect of bilateral contracts on the dynamics. It is possible to stabilize the system frequency and tie-power oscillations by controlling the phase angle of TCPS which is expected to provide a new ancillary service for the future power systems. A control strategy using TCPS is proposed to provide active control of system frequency. Further dynamic responses for small perturbation considering fuzzy logic controller and PI controller (dual mode controller) have been observed and the superior performance of fuzzy logic controller has been reported analytically and also through simulation.

© 2009 Elsevier Ltd. All rights reserved.

1. Introduction

Large scale power systems are normally composed of control areas or regions representing coherent groups of generators. In a practically interconnected power system, the generation normally comprises of a mix of thermal, hydro, nuclear and gas power generation. However, owing to their high efficiency, nuclear plants are usually kept at base load close to their maximum output with no participation in the system automatic generation control (AGC). Gas power generation is ideal for meeting the varying load demand. Gas plants are used to meet peak demands only. Thus the natural choice for AGC falls on either thermal or hydro units. Literature survey shows that most of earlier works in the area of AGC pertain to interconnected thermal systems and relatively lesser attention has been devoted to the AGC of interconnected hydrothermal system involving thermal and hydro subsystem of widely different characteristics. Kothari et al. [1] have investigated the AGC problem of a hydro-thermal system provided with integral type supplementary controllers. It is to be appreciated that in a realistic situation, the system works in the continuous mode whereas the controllers work in the discrete mode. Perhaps Nanda et al. [2] are the first to present comprehensive analysis of AGC of

an interconnected hydrothermal system in continuous-discrete mode with classical controllers.

Under deregulation the power system structure changed in such a way that would allow the evolving of more specialized industries for generation (Genco), transmission (Transco) and distribution (Disco). A detailed study on the control of generation in deregulated power systems is given in [3]. The concept of independent system operator (ISO) as an unbiased coordinator to balance reliability with economics has also emerged [4,5]. The assessment of automatic generation control in a deregulated environment is given in detail in [6,7] and also provides a detailed review over this issue and explains how an AGC system could be simulated after deregulation.

On the other hand, the concept of utilizing power electronic devices for power system control has been widely accepted in the form of FACTS which provide more flexibility in power system operation and control [8,9]. A Thyristor Controlled Phase Shifter (TCPS) is expected to be an effective apparatus for the tie-line power flow control of an interconnected power system.

However these authors have not considered the presence of nonlinearity like generation rate constraint and hence their work does not explain the working of AGC in deregulated environment in the presence of nonlinearities. A few investigations have been carried out using fuzzy logic controller (FLC) for AGC of thermal systems [10,11]. Surprisingly, till date, no attempt has been made to examine the effect of FLC in an interconnected hydro-thermal system under deregulated environment.

* Corresponding author.

E-mail addresses: csr_bit@yahoo.co.in, sirigiri70@yahoo.co.in (C.S. Rao), raju_ps_2000@yahoo.com (S.S. Nagaraju).

The remainder of the paper is organized as follows: Section 2 focuses on the dynamic mathematical model of two-area hydrothermal system. Section 3 deals with the design of FLC and its application to AGC. Section 4 explains the tie-line power flow model considering TCPS. Section 5 deals with the system investigation. Section 6 deals with results and discussions. In Section 7 some conclusions are drawn.

2. Dynamic mathematical model

Electric power systems are complex, nonlinear dynamic systems. The load frequency controller controls the control valves associated with high pressure (HP) turbine at very small load variations [12]. Here it is assumed that small variations of load permit the linearization of system equations. The system under investigation has tandem-compound single reheat type thermal system. Each element (Governor, turbine and power system) of the system is represented by first order transfer function at small load variations according to the IEEE committee report [13]. Nonlinearity like generation rate constraint (GRC) of 270%/min for thermal area and 4.5%/min for lowering generation in the hydro area is considered. Fig. 1 shows the transfer function block diagram of a two-area interconnected hydrothermal system. The parameters of two-area model are defined in Appendix.

3. Design of fuzzy logic controller

In this work we have designed PI-like Fuzzy Knowledge Based Controller. The area control error (ACE) and rate of change of ACE (ΔACE) are considered as the inputs to the fuzzy logic controller.

The basic structure of the conventional PI controller is given by

$$u = K_p e + K_I \int e dt \tag{1}$$

where K_p and K_I are the proportional and integral gains respectively and e is the error signal (i.e. $e = \text{process set point} - \text{process output variable}$). Taking the derivative with respect to time, (1) can be transformed into the following equivalent expression

$$\dot{u} = K_p \dot{e} + K_I e \tag{2}$$

For Automatic generation control problem the inputs to the fuzzy controller for i th area at a particular instant are $ACE_i(t)$ and $\Delta ACE_i(t)$, where $ACE_i(t) = \Delta P_{tiei} + B_i \Delta f_i$ and $\Delta ACE_i(t) = ACE_i(t) - ACE_i(t - 1)$ and output of the fuzzy controller is Δu . This is in accor-

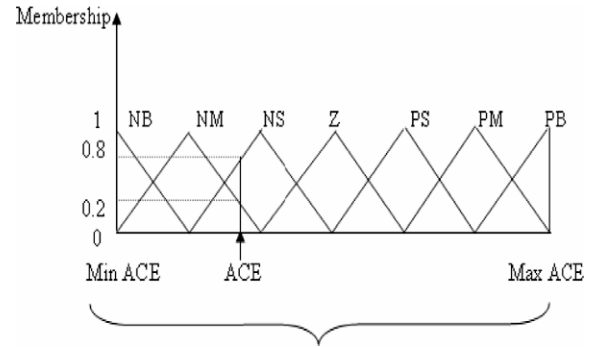

Fig. 2. Membership functions for the fuzzy variables of ACE.

Table 1
Fuzzy rules for two-area system.

	NB	NM	NS	Z	PS	PM	PB
NB	PB	PB	PM	PM	PS	PS	Z
NM	PB	PM	PM	PS	PS	Z	Z
NS	PM	PS	PS	PS	Z	Z	Z
Z	Z	Z	Z	Z	Z	Z	Z
PS	Z	Z	Z	NS	Z	NS	NS
PM	Z	Z	NS	NS	NM	NM	NB
PB	Z	NS	NS	NM	NM	NB	NB

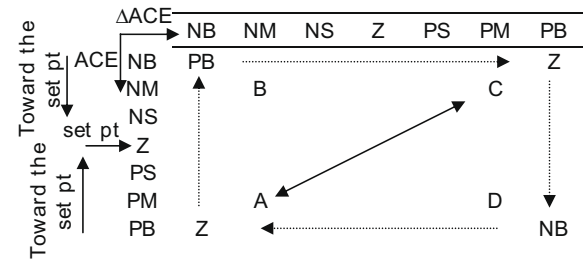

Fig. 3. Rules generation by understanding system dynamics.

dance with (2) for PI-like controller. The inputs and output are transformed to seven linguistic variables NB, NM, NS, Z, PS, PM and PB which stand for negative big, negative medium, negative small, zero, positive small, positive medium and positive big, respectively. Symmetrical triangular membership function is

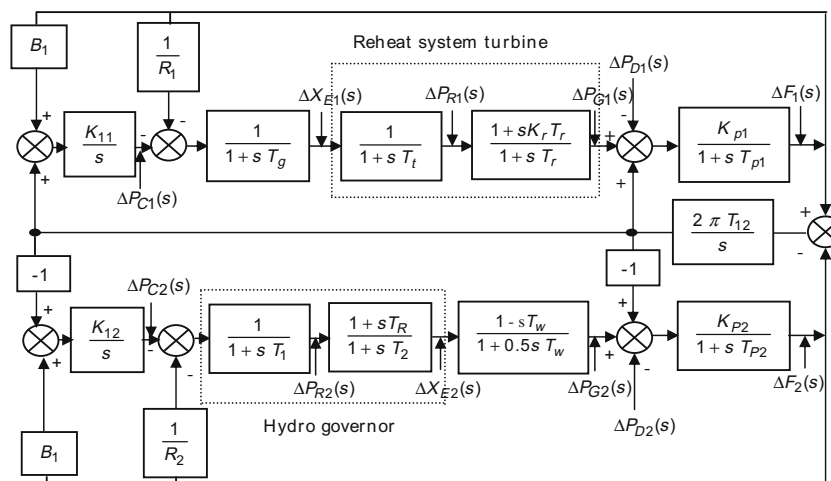

Fig. 1. Block diagram of two-area hydrothermal system.

متن کامل مقاله

دریافت فوری ←

ISIArticles

مرجع مقالات تخصصی ایران

- ✓ امکان دانلود نسخه تمام متن مقالات انگلیسی
- ✓ امکان دانلود نسخه ترجمه شده مقالات
- ✓ پذیرش سفارش ترجمه تخصصی
- ✓ امکان جستجو در آرشیو جامعی از صدها موضوع و هزاران مقاله
- ✓ امکان دانلود رایگان ۲ صفحه اول هر مقاله
- ✓ امکان پرداخت اینترنتی با کلیه کارت های عضو شتاب
- ✓ دانلود فوری مقاله پس از پرداخت آنلاین
- ✓ پشتیبانی کامل خرید با بهره مندی از سیستم هوشمند رهگیری سفارشات