



## Using institutional theory and dynamic simulation to understand complex e-Government phenomena

Luis Felipe Luna-Reyes<sup>a,\*</sup>, J. Ramon Gil-Garcia<sup>b</sup>

<sup>a</sup> Universidad de las Américas Puebla, Business School, Santa Catarina Mártir, Cholula, 72820, Mexico

<sup>b</sup> Centro de Investigación y Docencia Económicas (CIDE), Carretera México, Toluca No. 3655, México, D. F., 01210, Mexico

### ARTICLE INFO

Available online 17 May 2011

#### Keywords:

Institutional theory  
Technology enactment framework  
System dynamics  
Mexico  
e-Mexico  
Government portal

### ABSTRACT

Governments around the world have developed e-Government programs expecting to obtain important benefits such as improved efficiency or greater transparency. However, many e-Government projects fail to deliver their promises in terms of specific outcomes. Some of such failures are the result of a lack of understanding about the relationships among technologies, information use, organizational factors, institutional arrangements, and socio-economic contexts involved in the selection, implementation, and use of information and communication technologies (ICT), producing mismatches and unintended consequences. This paper proposes the use of institutional theory and dynamic simulation, particularly system dynamics, as an integrated and comprehensive approach to understand e-Government phenomena. Combining a sound theory and a sophisticated analytical technique will help to improve our understanding about ICT in government settings. The paper draws on the case of the e-Mexico program, particularly on the strategy to create web-based content portals for citizens in the areas of education, health, economy, and government. Using the same technological infrastructure and under the leadership of the same Federal Ministry, four different networks of government and non-government organizations engaged in the creation of internet portals and their content. The results provide evidence to demonstrate important bidirectional relationships between formal processes (institutions), agency networks (organizational forms), and the resulting characteristics of the four thematic portals (enacted technology).

© 2011 Elsevier Inc. All rights reserved.

### 1. Introduction

Electronic government (e-Government) has been recognized as a powerful strategy for government transformation. In the last 10 years, governments around the world have developed e-Government programs hoping to obtain important benefits such as cost savings, improved service quality, increased accountability, and more public participation, among others. However, many e-Government projects fail to deliver their promises in terms of specific outcomes (Heeks, 2003). Some such failures are the result of a lack of understanding about the complex relationships among technologies, information use, organizational factors, institutional arrangements, and socio-economic contexts involved in the selection, design, implementation, and use of information and communication technologies (ICT), producing mismatches and unintended consequences. In order to improve this situation, we need to put together theories and analytical techniques, which allow identifying and capturing the complexity of the relationships between relevant variables.

Therefore, it seems necessary to develop analytical approaches that combine a sound theoretical basis with innovative and sophisticated research methods. Within the last decade, several researchers around the world have been exploring such approaches. This paper illustrates one of these approaches, which has already proven to be useful and promise to be distinctively powerful in the near future given the complex and emergent nature of new ICTs and e-Government initiatives (Luna-Reyes, Black, Cresswell, & Pardo, 2008). The paper proposes the use of institutional theory and dynamic simulation, particularly system dynamics, as an integrated and comprehensive approach to understand e-Government phenomena. Institutionalism is a powerful theory that helps to understand the intertwined and complex nature of the relationships among technology, organizational factors, institutional arrangements, and the socio-economic context in which they are embedded (Fountain, 2001). System dynamics has also been an effective research method to understand complexity and time trends in e-Government and other ICT related domains.

This paper applies this integrated research approach to the case of the e-Mexico program, particularly to the strategy that created web-based content portals for citizens in the areas of education, health, economy, and government. Using the same technological infrastructure and under the leadership of the same Federal Ministry, four different networks of government and non-government organizations

\* Corresponding author. Fax: +52 222 229 2726.

E-mail addresses: [luisf.luna@udlap.mx](mailto:luisf.luna@udlap.mx) (L.F. Luna-Reyes), [joseramon.gil@cide.edu](mailto:joseramon.gil@cide.edu) (J.R. Gil-Garcia).

engaged in the creation of internet portals, which included relevant content in these four areas. The case is interesting because it illustrates the ways in which differences in institutional arrangements (formal processes) and organizational factors (agency networks) resulted on different technology enactments (characteristics of the technological artifacts and how they are perceived by social actors). Therefore, the purpose of this paper is twofold. First, it shows the importance of specific institutional arrangements and organizational forms on the characteristics of the resulting technology (enacted technology). It also demonstrates the recursive and complex nature of the relationships between these three variables: enacted technology, organizational forms, and institutions. Second, the paper shows the advantages of combining a sound theory and a sophisticated analytical technique in order to explain complex e-Government phenomena. Institutional theory is accepted as a powerful lens, but has been used at a very abstract level. System dynamics requires the specification of the variables and their relationships and, therefore, provides institutional theory with a systematic way to operationalize abstract theoretical concepts in specific and practically relevant variables. Together, they demonstrate the great explanatory power of sound theories and computer simulation as an integrated research approach.

The paper is organized in five additional sections after this introduction. The next section includes a brief review of institutional theory and the ways in which it is connected to system dynamics. The third section includes the data gathering and analysis methods. The fourth section is a description of the e-Mexico program, particularly its strategy on internet-based content creation. The fifth section describes a preliminary model based in the case, including some simulation experiments. Finally, the last section includes some conclusions and final remarks.

## 2. Literature review

We propose that institutional theory in general and the technology enactment framework in particular represent a powerful theoretical lens to explain specific information technology impacts (productivity, life style, etc.) for specific organizations or individuals and allow to understand the recursive and complex relationships between information technologies, organizational characteristics, institutional arrangements, and environmental conditions (Fountain, 2001; Gil-Garcia, 2005). Dynamic simulation, on the other hand, provides the appropriate methodological tool to get a better understanding of those relationships, results, and unintended consequences (Richardson & Pugh, 1981; Sterman, 2000). In the next sections, we briefly describe institutional theory, showing the technology enactment framework as a highly integrated and refined representation of institutional theory applied to ICT initiatives. Then, we briefly describe system dynamics as our preferred simulation approach.

### 2.1. Institutional theory

Researchers are increasingly realizing that complex interplays exist between ICT and the social context in which they are selected, developed, implemented, and used (Fountain, 2001; Kling, 2000; Orlikowski, 2000; Orlikowski & Iacono, 2001). Studies with this view propose that there is a recursive and complex relationship between information technologies and social structures and, as a consequence, the results of ICT projects are highly uncertain and cannot be easily predicted. In addition, these studies argue that ICT are not only the technological artifacts, but also the social and organizational aspects around those artifacts (Orlikowski & Iacono, 2001). Institutional theory is one of these more integrative approaches that recognize the importance of the context in which ICT are embedded and help to understand the influences of various factors on their selection, design, implementation, and use (Fountain & Gil-Garcia, 2006; Gil-Garcia, 2005).

Throughout the development of institutional theory, institutions have been conceptualized in many different ways. They are thought as guidelines for human action or appropriate behavior in society (March & Olsen, 1989). These guidelines are historically produced and reproduced and, therefore, are taken for granted and not questioned (Zucker, 1977). Institutions have been defined as mechanisms that are perceived as objective and constrain the behavior of individuals (Berger & Luckmann, 1966). They have been also conceptualized as ways to reduce uncertainty and increase cooperation in the political arena (Moe, 1984). Therefore, institutions are seen as rules of behavior based on various important foundations, from culture and mental models to legislation and from social norms to political structures. These different conceptualizations and foundations have been summarized in three pillars that represent or support institutions: cultural-cognitive, normative, and regulative (Scott, 2001).

Institutional theory has also been applied to the study of ICT in government settings and these studies have drawn on previous disciplinary efforts particularly from sociology, economics, and political science (Hassan & Gil-Garcia, 2008). We describe a recent institutional framework that integrates technology as a critical component of the analysis: the technology enactment framework. The technology enactment framework (Fountain, 1995, 2001) could be considered one of the most refined and integrated institutional approaches to the study of technology in organizations, particularly government agencies (see Fig. 1). Technology enactment focuses on the intersections between institutions, bureaucratic structures, and information technologies. The basic logic of this framework is that “objective technologies” (hardware, software, networks, etc.) are shaped by organizational forms and institutional arrangements to become “enacted technologies.” Similarly, organizational forms and institutional arrangements are affected by the selection, design, and use of ICT, acknowledging the bidirectional relationships between ICT and social structures (Orlikowski, 1992, 2000).

The enacted technology can be understood as the perception, design, and use of objective technologies such as the internet and different pieces of hardware and software (Fountain, 2001). At the organizational level, enacted technologies can be characterized as the features of the technology that are actually in place (they are included in the existing information system or systems) in contrast to all the features that could be potentially included (objective technology), but were not selected (Puron Cid & Gil-Garcia, 2004). The enacted technology produces certain organizational results or outcomes in terms of efficiency, effectiveness, and transparency, among others. These outcomes also affect the enacted technology, the organizational forms, and the institutional arrangements.

Organizational forms include structural characteristics such as centralization, formalization, and communication channels (Gil-Garcia, 2005). Other bureaucratic characteristics of the organizations are also included in this construct (Fountain, 2001). In contrast, institutional arrangements are laws, regulations, and other cognitive,

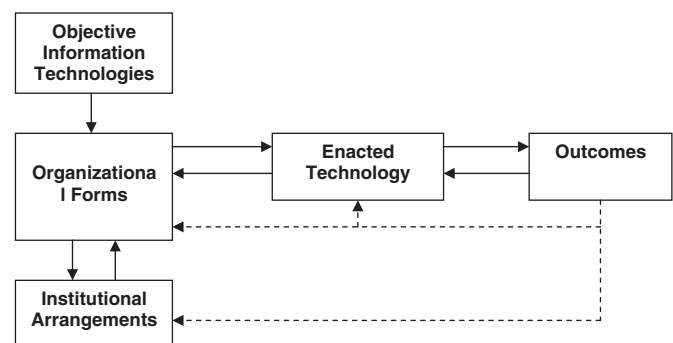

Fig. 1. Technology enactment framework (Fountain, 2001).

متن کامل مقاله

دریافت فوری ←

**ISI**Articles

مرجع مقالات تخصصی ایران

- ✓ امکان دانلود نسخه تمام متن مقالات انگلیسی
- ✓ امکان دانلود نسخه ترجمه شده مقالات
- ✓ پذیرش سفارش ترجمه تخصصی
- ✓ امکان جستجو در آرشیو جامعی از صدها موضوع و هزاران مقاله
- ✓ امکان دانلود رایگان ۲ صفحه اول هر مقاله
- ✓ امکان پرداخت اینترنتی با کلیه کارت های عضو شتاب
- ✓ دانلود فوری مقاله پس از پرداخت آنلاین
- ✓ پشتیبانی کامل خرید با بهره مندی از سیستم هوشمند رهگیری سفارشات