

Cascade nonlinear control of shunt active power filters with average performance analysis



Abdelmajid Abouloifa^a, Fouad Giri^{b,*}, Ibtissam Lachkar^b, Fatima Zahra Chaoui^c,
Mohamed Kissaoui^c, Younes Abouelmahjoub^c

^a University HASSAN II Casablanca-Mohammedia, FSBM, LTI Lab, Morocco

^b University of Caen Basse-Normandie, GREYC Lab UMR CNRS, 14032 Caen, France

^c University of Rabat-Souissi, ENSET, Rabat, Morocco

ARTICLE INFO

Article history:

Received 3 December 2011

Accepted 17 January 2014

Available online 21 February 2014

Keywords:

Active power filtering

Power factor correction

Nonlinear control

Stability analysis

Average analysis

ABSTRACT

The problem of controlling single-phase shunt active power filters is addressed in presence of nonlinear loads. The control objective is twofold: (i) compensation of harmonic and reactive currents absorbed by the nonlinear load, this objective is referred to as power factor correction (PFC); (ii) regulation of the inverter output capacitor voltage. A two-loop cascade control strategy is developed that includes an inner-loop designed, using the Lyapunov design approach, to cope with the compensation issue and an outer-loop designed to regulate the capacitor voltage. The controller performances are formally analysed using system averaging theory. The theoretical results are illustrated by simulation.

© 2014 Elsevier Ltd. All rights reserved.

1. Introduction

When a nonlinear electric load is supplied by a sinusoidal power supply net, current harmonics are generated causing the distortion of the voltage waveform at the point of common coupling (PCC). These harmonics not only disturb the supply net but also all loads and electronic equipments connected to the net. For a long time, the compensation of these harmonics has been coped with using passive LC filters and capacitor banks. The latter were resorted to improve AC loads power factor. This conventional solution is not only costly but also presents several shortcomings e.g. harmonic compensation is only partial, the LC filter may enter into resonance with the power net inductances. Therefore, efforts have been made by engineers and researchers, especially in power energy and power electronics areas, towards the development of alternative solutions to the power quality issues. In this respect, the concept of active power filter (APF) has emerged in the mid-1970s (Gyugyi & Strycula, 1976). Since then, many research programs have been conducted on active power filters and their practical applications (Akagi, 2005; Karagiannis, Mendes, Astolfi, & Ortega, 2003; Ramon, Robert, & Enric, 2004). With the emergence of semiconductor devices IGBTs and MOSFETs offering fast switching capability and digital signal processors (DSPs), field programmable gate arrays (FPGAs) and Hall Effect voltage/current sensors (of relatively low prices) the usage of active power

filters has become widespread. Nowadays, active power filters are undeniably preferred to conventional passive filters, due to their higher filtering capability, smaller physical size and higher flexibility. Among APFs configurations, shunt APF is mostly used in industrial scale products. In addition to their high cancellation capability (of load current harmonics), shunt APFs feature good reactive power compensation and current balancing (El-Habrouk, Darwish, & Mehta, 2000). The available APFs exist in two variants: single phase and triphase. Of course, the latter are higher power but the former enjoy lower cost and simpler control design (Aredes, 1996; Pottker de Souza, 2000). Consequently, there are practical situations where it proves to be much better to implement a low-power single phase APF at each single-phase of the nonlinear load, than installing a high power three-phase APF at the PCC.

The problem of controlling single-phase shunt APFs has been given a great deal of interest and several control strategies have been proposed over the last decade. In Doğan and Akkaya (2009), a fuzzy control design is considered and the control performances are illustrated by simulation. Unfortunately, the fuzzy approach does not make use of the available APF model making not possible a formal analysis of the closed-loop control performances. In Costa-Castelló, Griñó, Cardoner, and Fossas (2007), a simple linear PID controller has been proposed whose performances have been illustrated by experimental result. The nonlinearity of the controlled APF entails that optimal performances are not guaranteed on a wide range variation of the operation point. Nonlinear controllers, designed on the basis of accurate nonlinear models of the controlled APF, have

* Tel.: +33 231 56 72 87; fax: +33 231 56 73 40.
E-mail address: ouad.giri@unicaen.fr (F. Giri).

been proposed in Matas, de Vicuna, Miret, Guerrero, and Castilla (2008), Komurcugil (2006) and Hernandez (1998). The control design techniques used there include feedback linearization (Matas et al., 2008), sliding mode (Hernandez, 1998), and Lyapunov design (Komurcugil, 2006). These control solutions present at least two major drawbacks. First, all proposed controllers are mono-loop and designed to meet harmonic rejection. The output voltage regulation purpose is indirectly achieved by just letting the closed-loop system static gain equal unity. Accordingly, perfect asymptotic tracking is only guaranteed in presence of constant voltage reference and fixed loads. Second, no theoretical analysis is made to formally prove that the closed-loop control performances are actually achieved.

In this paper, the focus is made on single-phase shunt APFs in presence of nonlinear loads. A new control strategy is developed that overcome the above described shortcomings. Specifically, a nonlinear cascade controller is designed in order to simultaneously meet both control objectives: (i) satisfactory compensation of harmonic and reactive currents absorbed by the nonlinear load and (ii) tight regulation of the inverter output capacitor voltage. The controller inner-loop is designed using the Lyapunov design technique to cope with the compensation issue. The outer-loop involves a nonlinear PI regulator that regulates the output capacitor voltage despite load changes. It is formally shown using tools from the Lyapunov stability and averaging theory that, all control objectives are actually achieved in the mean. This theoretical result is confirmed by several numerical simulations.

The paper is organized as follows: the control problem formulation, including the APF modeling, is described in Section 2; the cascade nonlinear controller design is dealt with in Section 3 and its performances are formally analyzed in Section 4; the theoretical analysis results are confirmed by simulation in Section 4.

2. Control problem statement

2.1. APF topology and modelling

The single phase shunt APF under study has the structure of Fig. 1. It consists of a single-phase IGBT-based full-bridge inverter and an energy storage capacitor C_f , placed at the DC side. From the AC side, the APF is connected, in parallel with a nonlinear load, to the main AC voltage source through a filtering inductor L_f . The role of the APF is to produce reactive and harmonic components to compensate undesirable current harmonics produced by the nonlinear load. Doing so, the “filter-load” association behaves as a pure resistive load which amounts to make the fundamental component of load current in phase with the main AC voltage. The IGBT-based inverter operates in accordance to the well known Pulse

Width Modulation principle (PWM) (Andrieu, Ferrieux, & Rocher, 1996; Erickson, Madigan, & Singer, 1990; Krein, Bentsman, Bass, & Lesieutre, 1990; Tse & Chow, 2000). Finally, the supply net voltage v_{s0} (not accessible to measurement) is given by

$$v_{s0}(t) = E \sin(\omega_s t) \quad (1)$$

where E and ω_s denote, respectively, the amplitude and the angular frequency of $v_{s0}(t)$. The steady-state resulting load current is a periodic signal (with frequency ω_s) and so assumes a Fourier series expansion of the form:

$$i_c(t) = \sum_{n=1}^{\infty} I_{cn} \sin(n \omega_s t + \varphi_n) \quad (2)$$

Applying the usual Kirchhoff's laws to the single-phase shunt APF one easily gets:

$$L_s \frac{di_s}{dt} = v_{s0} - v_s - r_s i_s \quad (3a)$$

$$L_f \frac{di_f}{dt} = v_s - v \quad (3b)$$

$$C_f \frac{dv_o}{dt} = i_o \quad (3c)$$

The inverter undergoes the equations:

$$v = \mu v_o \quad (4a)$$

$$i_o = \mu i_f \quad (4b)$$

where the switching function μ of the inverter is defined by

$$\mu = \begin{cases} 1 & \text{if } (s_1, s_4) \text{ is ON, } (s_2, s_3) \text{ is OFF} \\ -1 & \text{if } (s_1, s_4) \text{ is OFF, } (s_2, s_3) \text{ is ON} \end{cases}$$

Combining (3) and (4), one obtains the instantaneous model of whole system:

$$L_s \frac{di_s}{dt} = v_{s0} - v_s - r_s i_s \quad (5a)$$

$$L_f \frac{di_f}{dt} = v_s - \mu v_o \quad (5b)$$

$$C_f \frac{dv_o}{dt} = \mu i_f \quad (5c)$$

The model (5) is useful for building up an accurate simulator of the inverter. However, it cannot be based upon in the control design as it involves a binary control input, namely μ . This kind of difficulty is generally coped with by resorting to average models. In this modelling context, signal averaging is performed over cutting intervals (e.g. Abouloifa et al., 2004) and the resulting average model is the following:

$$\frac{dx_{1,r}}{dt} = -\frac{r_s}{L_s} x_{1,r} + \frac{1}{L_s} x_{2,r} - \frac{v_s}{L_s} \quad (6a)$$

$$\frac{dx_{2,r}}{dt} = x_{3,r} \quad (6b)$$

$$\frac{dx_{3,r}}{dt} = -\omega_s^2 x_{2,r} \quad (6c)$$

$$\frac{dx_{1,f}}{dt} = -\frac{ux_{2,f}}{L_f} + \frac{v_s}{L_f} \quad (6d)$$

$$\frac{dx_{2,f}}{dt} = \frac{ux_{1,f}}{C_f} \quad (6e)$$

where $x_{1,r}$, $x_{1,f}$, $x_{2,f}$ and μ denote the average values, over cutting periods, of the signals i_s , i_f , v_o and μ . $x_{2,r} = v_{s0}$ and $x_{3,r} = \dot{v}_{s0}$ are a internal states of the, supposedly sinusoidal, voltage network.

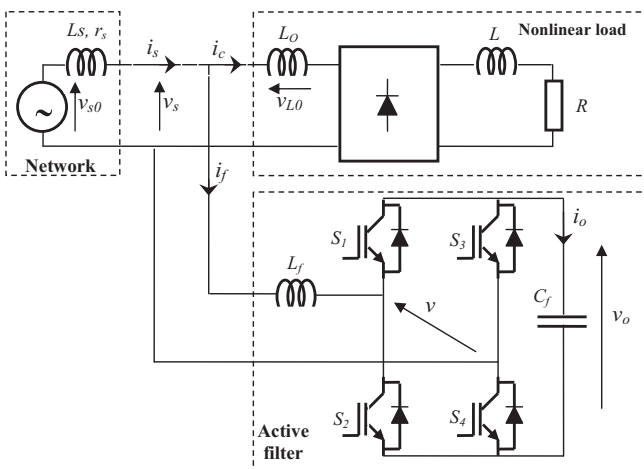

Fig. 1. Shunt filter connected to a “power net–load system” association.

متن کامل مقاله

دریافت فوری ←

ISIArticles

مرجع مقالات تخصصی ایران

- ✓ امکان دانلود نسخه تمام متن مقالات انگلیسی
- ✓ امکان دانلود نسخه ترجمه شده مقالات
- ✓ پذیرش سفارش ترجمه تخصصی
- ✓ امکان جستجو در آرشیو جامعی از صدها موضوع و هزاران مقاله
- ✓ امکان دانلود رایگان ۲ صفحه اول هر مقاله
- ✓ امکان پرداخت اینترنتی با کلیه کارت های عضو شتاب
- ✓ دانلود فوری مقاله پس از پرداخت آنلاین
- ✓ پشتیبانی کامل خرید با بهره مندی از سیستم هوشمند رهگیری سفارشات