

Active power flow control in a distribution system using discontinuous voltage controller

Sachin Goyal, Arindam Ghosh*, Gerard Ledwich

School of Engineering Systems, Queensland University of Technology, Brisbane, Qld 4001, Australia

ARTICLE INFO

Article history:

Received 4 December 2007
Received in revised form 14 May 2008
Accepted 6 June 2008
Available online 16 July 2008

Keywords:

UPS
Discontinuous current
Hybrid control
LC output filter and power flow control

ABSTRACT

This paper proposes a hybrid discontinuous control methodology for a voltage source converter (VSC), which is used in an uninterrupted power supply (UPS) application. The UPS controls the voltage at the point of common coupling (PCC). An LC filter is connected at the output of the VSC to bypass switching harmonics. With the help of both filter inductor current and filter capacitor voltage control, the voltage across the filter capacitor is controlled. Based on the voltage error, the control is switched between current and voltage control modes. In this scheme, an extra diode state is used that makes the VSC output current discontinuous. This diode state reduces the switching losses. The UPS controls the active power it supplies to a three-phase, four-wire distribution system. This gives a full flexibility to the grid to buy power from the UPS system depending on its cost and load requirement at any given time. The scheme is validated through simulation using PSCAD.

© 2008 Elsevier B.V. All rights reserved.

1. Introduction

The power quality issues such as harmonics, unbalancing, voltage sag/swell have gained considerable attention over the last few years. In addition, the concern for global warming has seen considerable development in the distributed generation (DG) technology in the recent time. An uninterruptible power supply (UPS) can provide solution for the power quality problem, while supplying clean power from DGs at the same time.

Usually UPSs are used to provide battery back up to computers and other data processing devices. They can be off-line type in which they remain idle until power failure occurs and start supplying power thereafter. The on-line type UPS continuously powers the protected load from its reserve while simultaneously replenishing the reserve by drawing power from the utility supply. A bi-mode UPS uses the ac–dc rectification for battery charging [1]. It then seamlessly picks up the load once a power failure occurs. Various configurations of UPS are reported in Ref. [2]. In Ref. [3], the design of an LC filter that is connected at the output of the UPS is discussed.

In this paper, the function of the UPS has been extended. It is assumed that the UPS is supplied by a distributed generator. The DG can be a PV stack or fuel cell stack [4] or battery which sup-

plies the dc bus of the voltage source converter (VSC) connecting the UPS to the ac grid. It is also possible to use PV or fuel cell to charge batteries that constitute the dc bus [5]. It is assumed that the UPS is connected at the point of common coupling (PCC) of the utility and a major load center. The UPS is then can be controlled in two different modes. In Mode-1, the utility supplies a constant power to the load and the remaining power comes from the UPS. In Mode-2, the UPS supplies a constant power to the load and the remaining power comes from the utility. An interchange between the modes can occur instantaneously. However, in both the modes, the UPS provides a balanced voltage at the PCC [6], thereby cancelling out any unbalance and harmonic content of the load and therefore enhancing the power quality of the distribution system.

Two different VSC control strategies are considered in this paper. The first strategy, proposed in this paper, uses both voltage and current control modes. In the voltage control mode, the modified concept of three-level hysteretic current control (HCC) given in [7,8] is used. Generally in a three-level HCC, the output of the converter is either $+V_{dc}$, 0 or $-V_{dc}$. In the zero state, a short circuit path is provided through converter. In this paper, the zero state is modified by a diode state. In the diode state, all four switches of a single-phase converter are turned off. Filter inductor current is made zero with the help of the diodes. The switching between the current and voltage control modes is based on the error in PCC voltage. If the error is large, the VSC operates in the current control mode and it is switched to the voltage control mode as the error reduces.

The performance of the proposed control strategy is compared with a three-level state feedback controller [9,10] for comparison of total harmonic distortion (THD) of PCC voltage, conduction and

* Corresponding author at: School of Engineering Systems, Queensland University of Technology, 2 George Street, GPO Box 2434, Brisbane, Qld 4001, Australia. Tel.: +61 7 3138 2459; fax: +61 7 3138 1516.

E-mail address: a.ghosh@qut.edu.au (A. Ghosh).

switching losses. Extensive simulation studies are performed using PSCAD and some of the results are presented in the paper.

2. Power flow control

The single-line diagram of a distribution system containing the UPS is shown in Fig. 1. For simplicity, it is assumed that the UPS is supplied from a battery with a dc voltage of V_{dc} . The load is assumed to be unbalanced and nonlinear. The load is connected at the far end of a feeder with an impedance of $R + j\omega L$, which is supplied by a source (v_s). An LC filter is connected at the output of VSC, the inductance and the capacitance of which are denoted by L_f and C_f , respectively, while the resistance R_f indicates the circuit losses. The PCC voltage is denoted by v_t .

2.1. The UPS model

Fig. 2 shows the structure of the UPS. It contains three H-bridge VSCs. All three VSCs are connected to common dc storage source V_{dc} . Each VSC is connected to grid through single-phase transformer and a capacitor. The three single-phase transformers are used to provide isolation [7]. Leakage inductance of transformer L_f and the filter capacitor C_f constitute the LC filter for each phase. All three transformers are connected in star and neutral point is connected

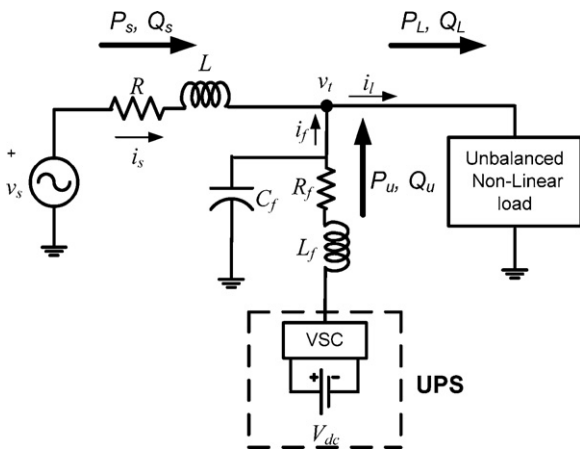

Fig. 1. Single-line diagram of the distribution system containing a UPS.

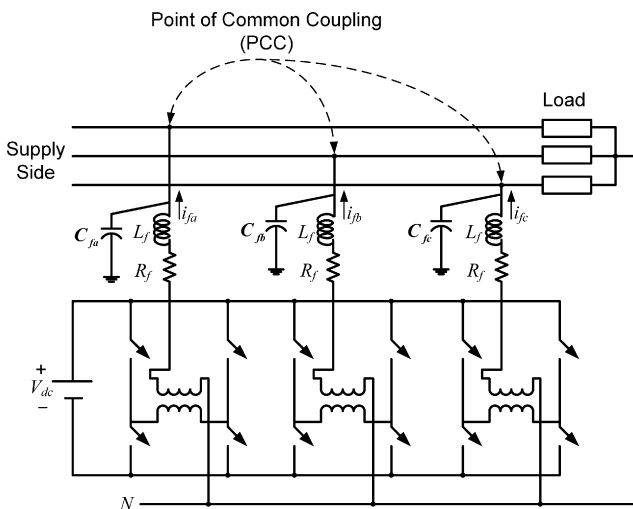

Fig. 2. UPS structure containing three VSCs that are supplied from a common dc source.

to the neutral of the load or it may be grounded if neutral point of load is not available. As far as structure of single-phase converter is concerned, it has four switches with anti-parallel freewheeling diode. In the later part of this paper, we shall see that output current of the converter, i.e., filter inductor current may be discontinuous. So diodes' rating must be same as IGBTs' rating.

The main purpose of the UPS is to maintain a balanced PCC voltage (v_t) irrespective of unbalance and distortion in the load currents. It also controls the magnitude of the PCC voltage to a pre-specified value even when there is a sag or swell in the source voltage. To control the power flow according to the modes described in the previous section, the angle of the PCC voltage must be controlled. Therefore the reference for the PCC voltage contains a pre-specified magnitude and an angle that is based on power requirements. The VSC then will have to track this reference voltage in order to achieve the desired performance.

2.2. Reference generation

Let us define the rms source and PCC voltages as

$$V_s = |V_s| \angle 0^\circ \text{ and } V_t = |V_t| \angle -\delta \quad (1)$$

Then from Fig. 1, we get the following expression for the active and reactive power entering the PCC from the source

$$P_s = \frac{|V_t|}{R^2 + X^2} [R(|V_s| \cos \delta - |V_t|) + X|V_s| \sin \delta] \quad (2)$$

$$Q_s = \frac{|V_t|}{R^2 + X^2} [X(|V_s| \cos \delta - |V_t|) - R|V_s| \sin \delta] \quad (3)$$

where $X = \omega L$. If $|V_s| \approx |V_t|$, the first term inside the bracket on the right hand side of Eq. (2) is negative. However, its influence on the positive valued second term is negligible as $R \ll X$. It is clear from Eq. (2) that real power flow can be controlled using δ . Because if δ is increased or decreased, the amount of real power can be increased or decreased accordingly. Therefore the reference PCC voltages are given by

$$\left. \begin{aligned} v_{refa} &= V_{tm} \sin(\omega t - \delta) \\ v_{refb} &= V_{tm} \sin(\omega t - \delta - 120^\circ) \\ v_{refc} &= V_{tm} \sin(\omega t - \delta + 120^\circ) \end{aligned} \right\} \quad (4)$$

where V_{tm} is a pre-specified magnitude and δ is controlled according to the power control mode.

2.2.1. Mode-1 control

In this mode, a fixed amount of active power is drawn from the source and the UPS supplies the balance amount of load requirement. As mentioned before, this can be achieved by controlling δ . This gives the following power control loop

$$\delta = K_{ps} e_s + K_{is} \int e_s dt + K_{ds} \frac{de_s}{dt} \quad (5)$$

where $e_s = P_{sref} - P_s$, P_{sref} is the reference power which is drawn from the source.

As mentioned earlier, the UPS must regulate the PCC voltage even during changed source voltage condition. Suppose a voltage sags occurs causing source voltage ($|V_s|$) to drop. As per requirement, the PCC voltage $|V_t|$ is still held constant. Hence from Eq. (2), it is evident that δ must increase in order to maintain the power flow constant. On the contrary, the angle δ must reduce during swell in the source voltage.

Also, it can be seen from Eq. (3) that reactive power (Q_s) is function of δ . Furthermore, since $|V_s| \cos \delta < |V_t|$, Q_s is negative. This means that the UPS supplies reactive power to the grid. As described above that at the time of sag in source voltage, δ is increased to

متن کامل مقاله

دریافت فوری ←

ISIArticles

مرجع مقالات تخصصی ایران

- ✓ امکان دانلود نسخه تمام متن مقالات انگلیسی
- ✓ امکان دانلود نسخه ترجمه شده مقالات
- ✓ پذیرش سفارش ترجمه تخصصی
- ✓ امکان جستجو در آرشیو جامعی از صدها موضوع و هزاران مقاله
- ✓ امکان دانلود رایگان ۲ صفحه اول هر مقاله
- ✓ امکان پرداخت اینترنتی با کلیه کارت های عضو شتاب
- ✓ دانلود فوری مقاله پس از پرداخت آنلاین
- ✓ پشتیبانی کامل خرید با بهره مندی از سیستم هوشمند رهگیری سفارشات