

A remote islanding detection and control strategy for photovoltaic-based distributed generation systems



Gökay Bayrak*

Nevşehir Hacı Bektaş Veli University, Faculty of Engineering and Architecture, Department of Electrical and Electronics, 50300 Nevşehir, Turkey

ARTICLE INFO

Article history:

Received 19 December 2014

Accepted 1 March 2015

Available online 13 March 2015

Keywords:

Distributed generation
Remote islanding detection
Grid-tied PV system
FPGA

ABSTRACT

This study presents a new remote islanding detection method and control system for photovoltaic (PV) based Distributed Generation (DG) systems. The proposed method monitors and controls the grid, local load and the output of the PV inverter in real time with the communication of circuit breakers. The proposed remote control system detects the changes in the currents of the circuit breakers, frequency, and the voltages by checking the defined threshold values at all electrical branches of the PV system. The proposed islanding detection algorithm was implemented by a low-cost FPGA board. The control system was also designed by considering a Very Large Scale Integration (VLSI) structure. The proposed method was verified by a developed prototype PV system constituted in the laboratory. The proposed control system was checked in a resonance condition with an active power match, and the verified results indicated that the developed system was also independent of the load and the inverter. Islanding detection time is approximately 1.65 ms even in a worst-case operational scenario, and this is a significantly shorter response time according to the existing standards. The proposed method presents a realistic solution to islanding, is easy to implement, and is suitable for real system applications. The method also provides a reliable islanding detection and presents a low-cost solution to the subject.

© 2015 Elsevier Ltd. All rights reserved.

1. Introduction

PV technology has developed rapidly over recent years such that solar energy has become the most important source of renewables [1]. Grid-tied PV systems have been coming into prominence in Distributed Generation (DG) systems in parallel to this development. There are some restrictions in connecting PV systems to utility grids such as the reliability of the grid, providing high power quality and safe interaction with the PV system. Islanding is maybe the most important issue in this restriction for PV systems, providing a reliable connection and continual operation with the grid.

Islanding operation is defined in a DG that a situation while a grid-tied PV system continues feeding the load, although disconnection of the electrical grid from the load [2]. Fig. 1 indicates a general schematic diagram of the grid-tied PV systems. Voltage and frequency of the system change from reference values in an islanding condition, so the grid disconnects from the grid-tied PV system without causing any damages to the system. Because of this, islanding detection methods have an important role in detecting the islanding in grid-tied PV systems.

The abnormal grid operating conditions negatively affect PV systems [3]. Islanding is the most significant security problem in a grid-tied PV system. Islanding operation can cause damage to both the PV system and the grid, and the grid voltage and the grid frequency are not stable in an islanding situation [4]. These conditions change from the grid reference values such that the circuit breaker (CB) connected between the grid and the point of common coupling (PCC) clears the fault during islanding mode. Meanwhile, DG still supplies power to the local load if the CB cannot open the circuit [5]. Voltage shutdown, equipment failure, and short-circuit conditions cause an unpredictable interruption of the grid, and these abnormal conditions cause islanding operation in a PV system [6]. Fig. 2 shows an islanding condition in a PV-based DG system [7].

There are two general types of islanding operations, intentional islanding and unintentional islanding [8]. Intentional islanding creates a power island when a disturbance occurs. An energy management plan is essential in an intentional islanding which is established to supply the local load consistently by DG [9]. Intentional islanding is a planned operation organized by the grid operators such that it is not harmful to the power system [10]. However, unintentional islanding can damage the grid due to loss of the synchronization of the electrical grid by causing a significant change in power system stability [11]. This situation causes the

* Tel.: +90 3842281000; fax: +90 3842281123.

E-mail address: gokaybayrak@gmail.com

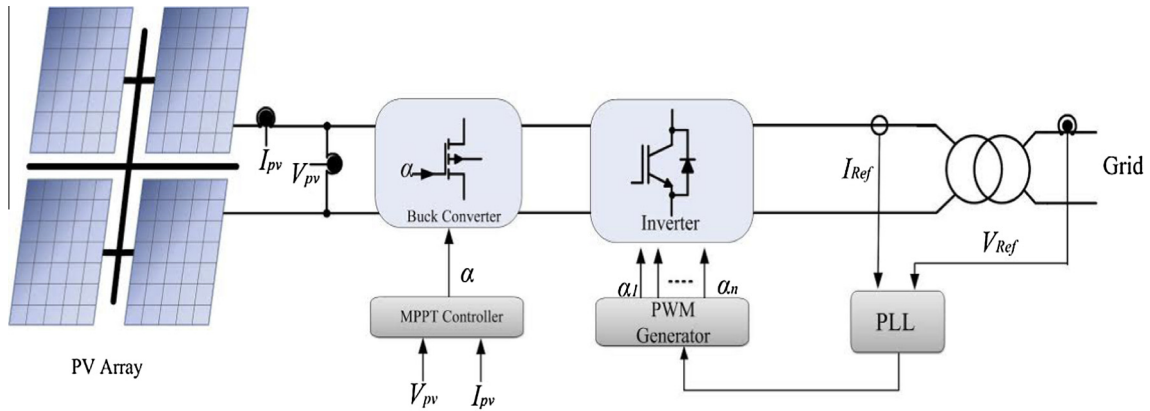

Fig. 1. A general schematic diagram of the grid-tied PV systems.

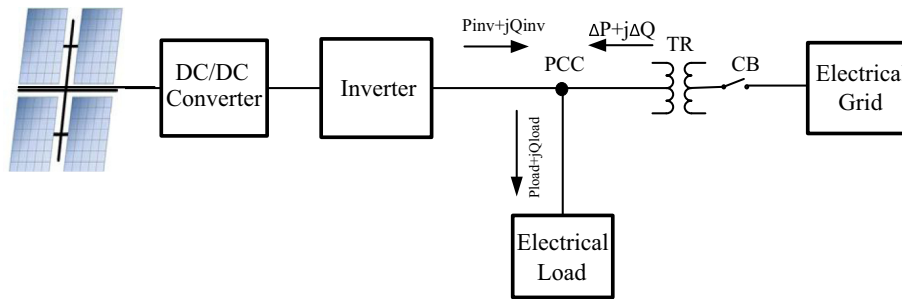

Fig. 2. Islanding in a PV-based DG system.

voltage and frequency to be out of desired grid reference ranges which can cause damage to the electrical devices and equipment of the system in the island DG section [12]. Because people working on the grid-tied PV system cannot realize that DG continues to supply power to the island part of the system, this situation presents a danger. The definition of this problem in a grid-tied PV system is an important criterion; islanding must be detected as soon as possible as indicated in IEEE standards [13]. This situation always should be considered carefully by authorized DG workers and companies.

Consequently, a DG containing a PV system should be disconnected from the local load by using a circuit breaker which is triggered by a generated control signal because of these restrictions [14]. There have been many developments in islanding detection methods and algorithms described in the literature [15].

2. Current islanding detection methods

There are two main methods, referred to as local and remote detection methods [16,17]. Remote methods are related to measuring system parameters at a DG. In this study, a new remote method between DG and the grid is used.

Islanding is an important problem to solve in PV based DG systems because it could cause serious problems with damaging equipment in PV system and the danger of death for working people. There have been some standards to define the rules and restrictions for grid-tied PV systems in islanding mode of operation. Mainly, IEEE-1547, IEEE 929, IEC-62116 and Japan standards are necessary for islanding.

IEEE 929-2000 also defines frequency threshold values, voltage threshold values and required opening time for circuit breaker (CB) in PV based micro-grid systems. Table 1 shows these definitions and threshold values. Islanding is detected according to the nominal voltage, and frequency values compared with specified values in IEEE 929-2000. Table 1 also indicates the opening time of circuit breaker in defining the conditions for the islanding mode of operation.

2.1. Passive islanding detection methods

Passive methods have a wide usage in PV based DG systems because of their smooth implementation and practical solution to the subject, and these techniques are the primary detection methods for detecting islanding. In addition, passive systems do not

Table 1
IEEE 929-2000 threshold values for grid connection.

No	Frequency	Voltage	CB opening time
1	f_{nom}	$0.5 V_{nom}$	6 cycles
2	f_{nom}	$0.5 V_{nom} < V < 0.88 V_{nom}$	2 s/120 cycles
3	f_{nom}	$0.88 V_{nom} \leq V \leq 1.10 V_{nom}$	Normal operation
4	f_{nom}	$1.10 V_{nom} < V < 1.37 V_{nom}$	2 s/120 cycles
5	f_{nom}	$1.37 V_{nom} \leq V$	2 cycles
6	$(f_{nom} - 0.7) \leq f \leq (f_{nom} + 0.5)$ Hz	V_{nom}	Normal operation
7	$f < (f_{nom} - 0.7)$ Hz	V_{nom}	6 cycles
8	$f > (f_{nom} + 0.5)$ Hz	V_{nom}	6 cycles

متن کامل مقاله

دریافت فوری ←

ISIArticles

مرجع مقالات تخصصی ایران

- ✓ امکان دانلود نسخه تمام متن مقالات انگلیسی
- ✓ امکان دانلود نسخه ترجمه شده مقالات
- ✓ پذیرش سفارش ترجمه تخصصی
- ✓ امکان جستجو در آرشیو جامعی از صدها موضوع و هزاران مقاله
- ✓ امکان دانلود رایگان ۲ صفحه اول هر مقاله
- ✓ امکان پرداخت اینترنتی با کلیه کارت های عضو شتاب
- ✓ دانلود فوری مقاله پس از پرداخت آنلاین
- ✓ پشتیبانی کامل خرید با بهره مندی از سیستم هوشمند رهگیری سفارشات