

New multi-stage DC–DC converters for grid-connected photovoltaic systems



Yihua Hu^a, Wenping Cao^{b,*}, Bing Ji^c, Jikai Si^d, Xiangping Chen^e

^a Department of Electronic & Electrical Engineering, Strathclyde University, G1 1XQ, UK

^b School of Electronics, Electrical Engineering and Computer Science, Queen's University Belfast, Belfast BT9 5AH, UK

^c School of Electrical and Electronic Engineering, Newcastle University, NE1 7RU, UK

^d School of Electrical Engineering and Automation, Henan Polytechnic University, Henan, China

^e College of Electrical Engineering, Guizhou University, Guiyang, China

ARTICLE INFO

Article history:

Received 2 January 2014

Accepted 4 August 2014

Available online 24 August 2014

Keywords:

DC–DC power conversion

Harmonic distortion

Hysteresis

Converters

Multilevel systems

Photovoltaic power systems

ABSTRACT

Renewable energy is high on international and national agendas. Currently, grid-connected photovoltaic (PV) systems are a popular technology to convert solar energy into electricity. Existing PV panels have a relatively low and varying output voltage so that the converter installed between the PVs and the grid should be equipped with high step-up and versatile control capabilities. In addition, the output current of PV systems is rich in harmonics which affect the power quality of the grid. In this paper, a new multi-stage hysteresis control of a step-up DC–DC converter is proposed for integrating PVs into a single-phase power grid. The proposed circuitry and control method is experimentally validated by testing on a 600 W prototype converter. The developed technology has significant economic implications and could be applied to many distributed generation (DG) systems, especially for the developing countries which have a large number of small PVs connected to their single-phase distribution network.

© 2014 Elsevier Ltd. All rights reserved.

1. Introduction

With increasing concerns over global warming and the depletion of fossil fuels, substantial investment and effort has been directed towards developing renewable energy technologies. The clean electricity generation based on photovoltaic (PV) technologies is one of the prevalent solutions. In the literature, there are three reported types of grid-connected PV system configurations reported: the central type, string type and modularized type [1–3], as depicted in Fig. 1. The first systems connect PV modules in series and then in parallel so as to increase their direct current (DC) bus voltage and power. They generally have high-voltage high-current output and are suited for large-scale (>5 kW) three-phase systems. But they suffer from high power losses and high current harmonics, PV module mismatch and shade effects [4]. The second require an individual maximum power point tracking (MPPT) for each string [5,6]. They have high-voltage low-current output, and they are efficient and suitable for medium-scale (2–5 kW) single-phase systems. In contrast, the third type of systems requires an individual power converter and MPPT for each PV module. As a result,

these systems typically have low-voltage low-current output and require high capital investment. They are limited to small-scale (<2 kW) single-phase systems. In practice, the second configuration is the dominant type in PV applications and is therefore the focus of this paper.

In theory, the output voltage of one PV string is very low and varies over a wide range despite the use of MPPT. This requires the front-end DC–DC converter to be equipped with a step-up capability for grid connection [7–12] at the expense of power quality. In this case, the multilevel converter technology is advantageous to incorporate PVs into the power grid while achieving good output waveforms, reduced filter sizes and reduced electromagnetic interference (EMI) [13–15]. However, these converters are complex, costly, and low in voltage amplification. Therefore, it is desired to develop an advanced converter combining features of high step-up and multilevel so as to reduce the number of active switching devices in the converter.

When connected to a power network, the PV systems must meet stringent power quality requirements set by the utility including low total harmonic distortion (THD) and fast dynamic response. In this regard, hysteresis current control is often chosen owing to its simplicity, robustness and good large-signal response. Nevertheless, the switching frequency of the converter varies with the bus

* Corresponding author. Tel.: +44 (0)28 90974058.

E-mail address: w.cao@qub.ac.uk (W. Cao).

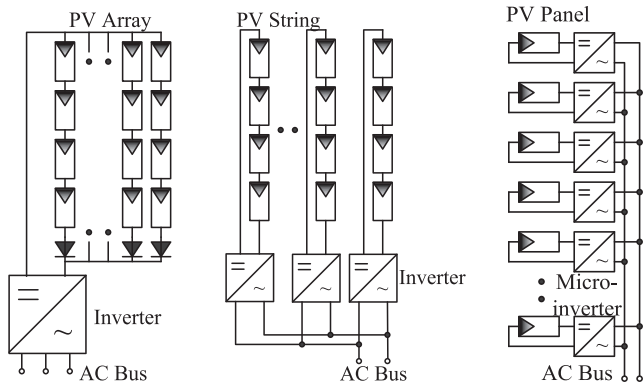

(a) The central type. (b) The string type. (c) The modularized type.

Fig. 1. Three types of PV system configurations.

voltage, filter inductance and bandwidth [16–18]. In the literature, the variable-hysteresis-band current control technique [16,19] and digital hysteresis modulation technique [20] are reported in use. They require multiple samples within a switching period and are thus complicated and computationally costly. Moreover, these hysteresis control methods are hardly used for asymmetric multilevel converters [21] which are the case for this study.

To tackle the problem, this paper proposes a new asymmetry multilevel DC–DC converter with improved hysteresis control. Section 2 introduces the proposed converter topology. Section 3 discusses an improved hysteresis control scheme. Section 4 presents and analyzes the simulation and experimental results for validation purposes, followed by a brief conclusion in Section 5.

2. Proposed multilevel converter

The proposed topology consists of a high step-up DC–DC converter, a three-level DC–DC converter and a line frequency commutated bridge. See Fig. 2 for details.

2.1. High step-up DC–DC converter

The equivalent circuit of the proposed converter is shown in Fig. 3. In the figure, S_0 is the main switch, D_0 and D_2 are the regenerative diodes, D_1 is the rectifier diode, C_1 and C_2 are the output filter capacitors, C_s is the bootstrap capacitor, R is the load, U_{in} and U_{dc} are the input and output voltages, respectively. A coupled inductor L_c with primary and secondary turns of N_p and N_s is also used to increase voltage gain. It is equivalent to an ideal transformer whose primary winding connected in parallel with a magnetizing inductor L_m and then in series with a leakage inductance L_p .

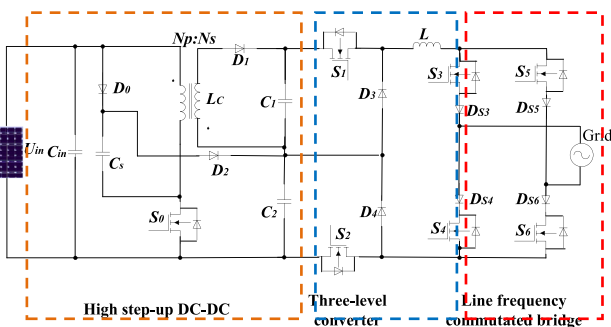

Fig. 2. The proposed high step-up multilevel converter.

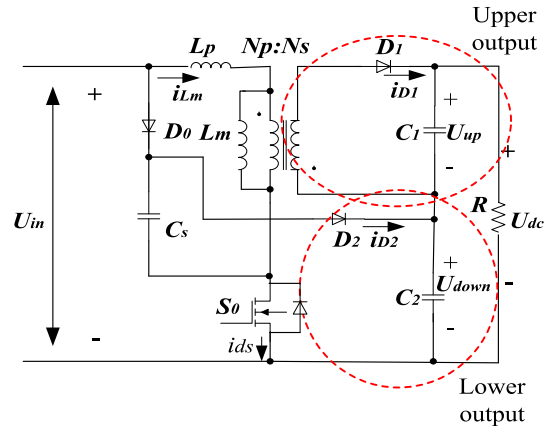
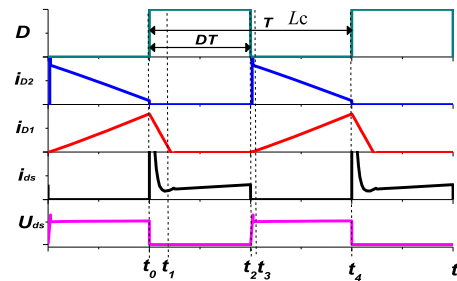

Fig. 3. Equivalent circuit of the high step-up DC–DC converter.

The converter operates on two modes: continuous and discontinuous conduction, depending on the load.

2.1.1. Continuous conduction mode

Voltage and current waveforms of the high step-up DC–DC converter in the continuous conduction mode (CCM) are presented in Fig. 4(a) and four stages and current flow paths are shown in Fig. 4(b)–(e) for one full period and explained in detail as follows.



(a) Waveforms of the main devices

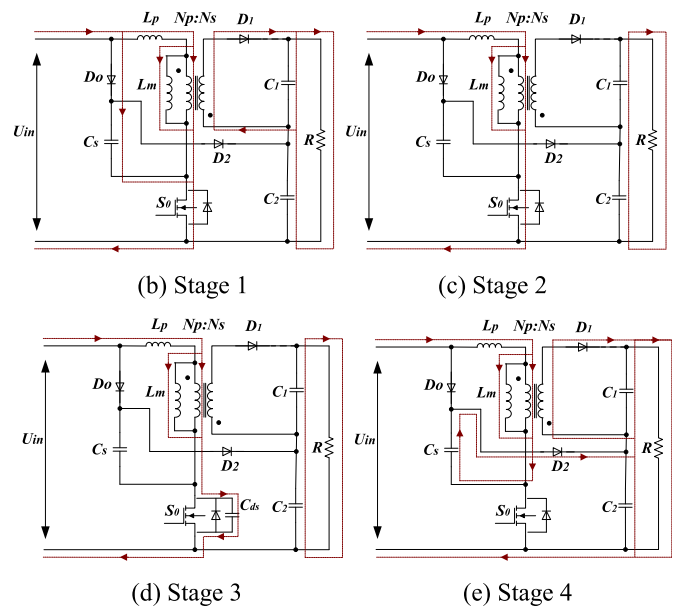

Fig. 4. Operation of the CCM during a period (T is the period and D is the duty ratio).

متن کامل مقاله

دریافت فوری ←

ISIArticles

مرجع مقالات تخصصی ایران

- ✓ امکان دانلود نسخه تمام متن مقالات انگلیسی
- ✓ امکان دانلود نسخه ترجمه شده مقالات
- ✓ پذیرش سفارش ترجمه تخصصی
- ✓ امکان جستجو در آرشیو جامعی از صدها موضوع و هزاران مقاله
- ✓ امکان دانلود رایگان ۲ صفحه اول هر مقاله
- ✓ امکان پرداخت اینترنتی با کلیه کارت های عضو شتاب
- ✓ دانلود فوری مقاله پس از پرداخت آنلاین
- ✓ پشتیبانی کامل خرید با بهره مندی از سیستم هوشمند رهگیری سفارشات