

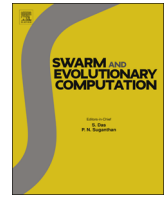

ELSEVIER

Contents lists available at ScienceDirect

Swarm and Evolutionary Computation

journal homepage: www.elsevier.com/locate/swevo

Regular Paper

Evolutionary optimization technique for comparative analysis of different classical controllers for an isolated wind–diesel hybrid power system



Tarkeshwar Mahto, V. Mukherjee*

Department of Electrical Engineering, Indian School of Mines, Dhanbad, Jharkhand, India

ARTICLE INFO

Article history:

Received 14 January 2015

Received in revised form

9 April 2015

Accepted 9 September 2015

Available online 24 September 2015

Keywords:

Classical controllers

Frequency

Harmony search algorithm

Isolated hybrid wind diesel power system

Power and PID controller

ABSTRACT

In this paper, the considered hybrid power system (HPS) is having a wind turbine generator, a diesel engine generator (DEG) and a storage device (such as capacitive energy storage). This paper presents a comparative study of frequency and power control for the studied isolated wind–diesel HPS with four different classical controllers for the pitch control of wind turbines and the speed governor control of DEG. The classical controllers considered are integral, proportional-integral, integral-derivative and proportional-integral-derivative (PID) controller. A quasi-oppositional harmony search (QOHS) algorithm is proposed for the tuning of the controller gains. The comparative dynamic simulation response results indicate that better performance may be achieved with choosing PID controller among the considered classical controllers, when subjected to different perturbation. Stability and sensitivity analysis, presented in this paper, reveals that the optimized PID controller gains offered by the proposed QOHS algorithm are quite robust and need not be reset for wide changes in system perturbations.

© 2015 Elsevier B.V. All rights reserved.

1. Introduction

Installation and supply of electricity through grid in remote and sparsely populated areas poses serious logistics for the developing economics. This is one of the main reason for the large volume of research works, currently, being carried out in the field of standalone renewable energy sources (RESs) and hybrid power systems (HPSs) which combine one or more different types of RESs (e.g. photovoltaic, micro turbine, wind turbine, fuel cells etc.) [1] and low carbon generators (e.g. diesel generators) along with storage devices. Some other major reasons are the depletion of fossil fuel reserves (i.e. coal and oil), global warming and enormous growth in global population and, hence, in energy demand [2]. Solar and wind energy are most abundantly available in nature from the catalog of RESs. Wind turbine generators (WTGs) have a cutting edge over photovoltaic module in producing power more cost effectively and efficiently. Hence, WTG has got much importance from the researchers' pool.

The intermittent power output of WTG may cause power fluctuation and it may also cause a serious problem of frequency fluctuation of the system [3]. To improve the quality of produced

power and for uninterrupted power supply, WTG based system is coupled with diesel engine generator (DEG) and with an energy storage device such as capacitive energy storage (CES), as in this case. A HPS of this type may be termed as isolated hybrid wind–diesel power system (IHWDPSS). The IHWDPSS may supply quality power to the consumers if the installed controllers are, optimally, tune.

Despite of lot of progresses in the field of meta-heuristic approaches for the optimization problem, there are, possibly, some more avenues to improve on their searching capabilities, stabilities and convergence characteristics. A new intelligent optimization technique, called harmony search (HS), is developed by Geem et al. [4]. This algorithm has found a number of successful applications in some real world problems [5,6] in the recent years. HS has been used for static economic load dispatch problems [7–9]. HS is able to identify the high performance regions in the solution space but it does not have a good local searching capability [10] and also requires large number of design parameters for each specific problem. To overcome this drawback of HS algorithm, several variants of HS algorithm have been proposed in the literature to enhance its fine tuning capability and to reduce its number of design parameters. An adaptive strategy for setting parameters, namely, improved HS was introduced in [10]. Global best concept of particle swarm optimization (PSO) combined with HS was proposed in [11]. Self-adaptive global best HS was proposed in [12] which combines the aforementioned two

* Corresponding author. Tel.: +91 326 2235644; fax: +91 326 2296563.

E-mail addresses: tara.mahto@gmail.com (Tarkeshwar Mahto), vivek_agamani@yahoo.com (V. Mukherjee).

improvements. The exploratory power of HS algorithm was investigated in [13]. Further, incorporation of the opposition learning concept in HS was purposed in [9] and termed as opposition based HS (OHS) algorithm. All these HS variants have shown their superiority in different applications.

However, in the present paper, a novel yet simple HS algorithm with a new population initialization concept, namely quasi-opposition based learning (QOBL) is introduced. QOBL does not use neither random initialization of its population nor random number with their opposite number rather it uses random number population with its quasi-opposite number aiming at to (a) enhance the performance, (b) overcome the premature convergence, (c) improve the diversity of the solutions and (d) accelerate the convergence speed of the basic HS algorithm. Thus, in the current study, quasi-oppositional HS (QOHS) algorithm has been developed for solving both frequency and power deviation problems of the studied IHWDPs model.

In view of the above, the main objectives of the present work are to

- develop the model of an IHWDPs for supplying quality power to the consumer,
- employ QOHS algorithm for the sake of optimization of the controller gains of several classical controllers such as integral (I), proportional-integral (PI), integral-derivative (ID) and proportional-integral-derivative (PID) installed in the studied IHWDPs model, considering one at a time,
- compare the dynamic performances offered by the controllers to find out the best one among these four for this specific application,
- incorporate time delay module and generation rate limiter for DEG with an aim to deal with a more realistic system configuration,
- analyze the stability of the studied models through Bode plot and to carry out eigenvalue sensitivity analysis through eigenvalue plots,
- present large signal stability study by considering generation outage from DEG,
- study the comparative convergence profiles of some meta-heuristics, applied for the present application and
- study the robustness of the optimum gains of the best controller obtained for wide changes in system loading conditions.

The rest of paper is structured as follows. System component modeling is done in Section 2, followed by controller design methodology in Section 3. Mathematical problem of the present work is formulated in Section 4. In Section 5, proposed QOHS algorithm is focused. Simulations results are presented and analyzed in Section 6, followed by conclusion and scope of future work in Section 7.

2. IHWDPs components modeling

An IHWDPs consisting of a DEG, a WTG and a CES device is considered for the present study and is shown in Fig. 1. It comprises of a speed governor in DEG, the blade pitch controller in WTG for frequency and power control of the model and the CES block is also added to improve the system dynamic performance. The dynamics of the wind power generating unit is described by a first order system. A higher order model may, however, be considered if the slow dynamics of the mechanical parts are to be integrated [14].

Clean wind power is harnessed by the WTG system and DEG are integrated with WTG system for compensating the unpredictable fluctuation in wind power and to cater the varying load demand. For maintaining the desired power and to ensure uninterrupted power, CES device is connected to the system at the load terminals. Moreover, continuous use of DEG is not envisaged as it is costly and noisy accompanied by harmful emissions [15]. The operation of the studied HPS may be stated follows:

- Under normal modes of operation, the WTG will supply power to the load. Excess energy may be stored in the CES device to its maximum capacity. Any further excess energy may be fed into a resistive dump load.
- Under any abnormal condition (like unavailability of sufficient energy either from the WTG system and/or from CES device for supplying to the load demand), the DEG will, automatically, supply the load directly or by charging the CES device [16].

From Fig. 1, the incremental change in total power may be written by (1):

$$\Delta P_{TOTAL} = \Delta P_{GD} + \Delta P_{GW} - \Delta P_{CES} - \Delta P_L \quad (1)$$

The components involved in the right side of (1) are described in the next sub-sections.

2.1. Mathematical modeling of DEG

The RESs have intermittent output characteristics and these are integrated with conventional power sources to deliver a steady output power. In the considered IHWDPs, DEG acts as a steady source of power. When the power produced by WTG is not enough and the energy of storage system energy is at the lowest level (CES in this case), DEG system begins to work. The DEG should have limited time of operation in order to reduce the wear and tear as the life of DEG is inversely proportional to the energy supplied by it.

From Fig. 1, the modeling equations of DEG, in s-domain, may be given by (2)–(4):

$$\Delta P_{GD} = \left(\frac{1}{1+sT_{D4}} \right) \Delta P_{GT} \quad (2)$$

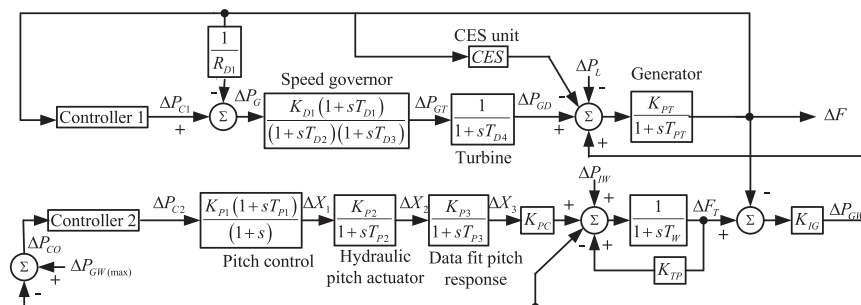

Fig. 1. Transfer function block diagram of the studied IHWDPs.

متن کامل مقاله

دریافت فوری ←

ISIArticles

مرجع مقالات تخصصی ایران

- ✓ امکان دانلود نسخه تمام متن مقالات انگلیسی
- ✓ امکان دانلود نسخه ترجمه شده مقالات
- ✓ پذیرش سفارش ترجمه تخصصی
- ✓ امکان جستجو در آرشیو جامعی از صدها موضوع و هزاران مقاله
- ✓ امکان دانلود رایگان ۲ صفحه اول هر مقاله
- ✓ امکان پرداخت اینترنتی با کلیه کارت های عضو شتاب
- ✓ دانلود فوری مقاله پس از پرداخت آنلاین
- ✓ پشتیبانی کامل خرید با بهره مندی از سیستم هوشمند رهگیری سفارشات