



Load frequency controller design via BAT algorithm for nonlinear interconnected power system



S.M. Abd-Elazim, E.S. Ali ^{*,1}

Electric Power and Machine Department, Faculty of Engineering, Zagazig University, Zagazig, Egypt

ARTICLE INFO

Article history:

Received 7 April 2014

Received in revised form 17 October 2015

Accepted 17 November 2015

Available online 7 December 2015

Keywords:

BAT algorithm

Simulated Annealing

Load frequency control

PI controller

Nonlinear system

Low frequency oscillations

ABSTRACT

BAT algorithm is proposed in this paper for optimal tuning of PI controllers for load frequency controller (LFC) design. The problem of robustly tuning of PI based LFC design is formulated as an optimization problem according to time domain objective function that is solved by BAT algorithm to find the most optimistic results. To demonstrate the effectiveness of the proposed method, a two-area interconnected power system is considered as a tested system. To ensure robustness of the proposed control strategy to stabilize frequency oscillations, the design process takes a wide range of operating conditions and system nonlinearities into account. The simulation results are given to detect the superiority of BAT algorithm over Simulated Annealing (SA) in tuning PI controller parameters through different indices. Results evaluation show that the proposed algorithm achieves good robust performance for wide range of system parameters and load changes compared with SA.

© 2015 Elsevier Ltd. All rights reserved.

Introduction

In the large scale electric power systems with interconnected areas, Load Frequency Control (LFC) plays an important role. The LFC is aimed to maintain the system frequency of each area and the inter-area tie line power within tolerable limits to deal with the fluctuation of load demands and system disturbances [1,2]. These important functions are delegated to LFC due to the fact that a well-designed power system should keep voltage and frequency in scheduled range while providing an acceptable level of power quality [3,4].

During the last decades several researches and techniques had been applied to the field of LFC. Robust control [5–12], pole placement approach [13,14], variable structure control [15], and state feedback [16], are used to deal with LFC problem design. These strategies have some disadvantages such as high order controller, difficulty, complexity and inapplicable to implement. In an effort to overcome aforementioned disadvantages, several researches have used Artificial Intelligence (AI) approaches such as Fuzzy Logic Controller (FLC) [17–23] and Artificial Neural Network (ANN) [24–27]. Although these methods are effective in dealing

with the nonlinear characteristics of power system, they require extensive computation. For example, FLC has to deal with fuzzification, rule base storage, inference mechanism, and defuzzification operations. For ANN, the large amount of data required for training are a major source of constraint. Clearly, a low-cost processor cannot be employed in such a system.

An alternative approach is to employ Evolutionary Algorithm (EA) techniques. Due to its ability to handle nonlinear objective functions, EA is visualized to be very effective to deal with LFC problem. Among the EA techniques, Genetic Algorithm (GA) [28–33], Particle Swarm Optimization (PSO) [34–38], Ant Colony Optimization (ACO) [39], Bacteria Foraging (BF) [40–44] and Artificial Bee Colony (ABC) [45,46] have attracted the attention in LFC controller design. However, these algorithms appear to be effective for the design problem, they pain from slow convergence in refined search stage, weak local search ability and may lead to possible entrapment in local minimum solutions. Recently, a new evolutionary computation algorithm, called BAT algorithm has been presented by [47] and further established recently by [48–53]. It is a very simple and robust population based optimization algorithm. Moreover, it requires less control parameters to be tuned. Hence, it is suitable optimization tool for power system controller design.

This paper proposes BAT algorithm for optimal tuning of PI controllers. The motivation behind this research is to ensure and prove the robustness of BAT based PI controller in enhancing the performance of both frequency deviation and tie line power under various loading conditions in presence of system nonlinearities.

* Corresponding author at: Faculty of Engineering, Zagazig University, Zagazig 44519, Egypt. Tel.: +20 11 2669781, +20 55 2321407.

E-mail addresses: sahareldeep@yahoo.com (S.M. Abd-Elazim), ehabsalimalisalama@yahoo.com (E.S. Ali).

¹ Present address: Electrical Department, Faculty of Engineering, Jazan University, Saudi Arabia.

Nomenclature

f the system frequency in Hz
 i subscript referring to area ($i = 1, 2$)
 R_i the regulation constant (Hz/p.u MW) for area i
 T_{gi} the speed governor time constant in second for area i
 T_{ti} the turbine time constant in second for area i
 T_{ri} the reheat time constant in second for area i
 K_{ri} the p.u megawatt rating of high pressure stage for area i
 T_w the hydro turbine time constant
 T_{Pi}, K_{Pi} the time constant and gain of power system respectively for area i
 ΔP_{tie_i} the difference between the actual tie-line power and scheduled one
 B the biasing factor in pu MW/Hz
 K_{ppi}, K_{iii} the gains of PI controller of area i
 N the number of area in power systems
 t_{sim} the simulation time in second
 t time in second
 T_{ij} synchronizing coefficient
 J objective function
 U_i the control signal of area i
 K_i the controller of area i
 $K_{ppi}^{min}, K_{ppi}^{max}$ the lower and the upper limit of proportional gain of area i
 $K_{iii}^{min}, K_{iii}^{max}$ the lower and the upper limit of Integral gain of area i
 x_i the position of each bat

v_i the velocity of each bat
 L^t the mean loudness
 x_i^t the new position
 v_i^t the new velocity
 F_{min}, F_{max} the minimum and maximum frequency

List of abbreviations

LFC load frequency control
 GA Genetic Algorithm
 PSO Particle Swarm Optimization
 AI Artificial Intelligence
 FLC Fuzzy Logic Controller
 ANN Artificial Neural Network
 ACO Ant Colony Optimization
 BF Bacteria Foraging
 ABC Artificial Bee Colony
 PI Proportional plus Integral
 GRC Generation Rate Constraint
 ACE Area Control Error
 IAE the Integral of Absolute value of the Error
 ITAE the Integral of the Time multiplied Absolute value of the Error
 ISE the Integral of Square Error
 ITSE the Integral of Time multiply Square Error

Two area power system

A two area model of a hydrothermal power station including nonlinearities is shown in Fig. 1. Area 1 is reheat thermal system and area 2 is a hydro system [39]. The steam chest time constant which is related to the non-reheat stage ranges from 0.1 to 0.5 s

whereas the time constant for the reheat stage ranges from 4 to 10 s. Nonlinearities are represented in Generation Rate Constraint (GRC) and governor dead band. The first one as its name implies GRC that illustrates the limitation on the generation rate due to the limitation of thermal and mechanical movements [4], for thermal stations it is taken to be 0.1 pu Mw per minute. The second

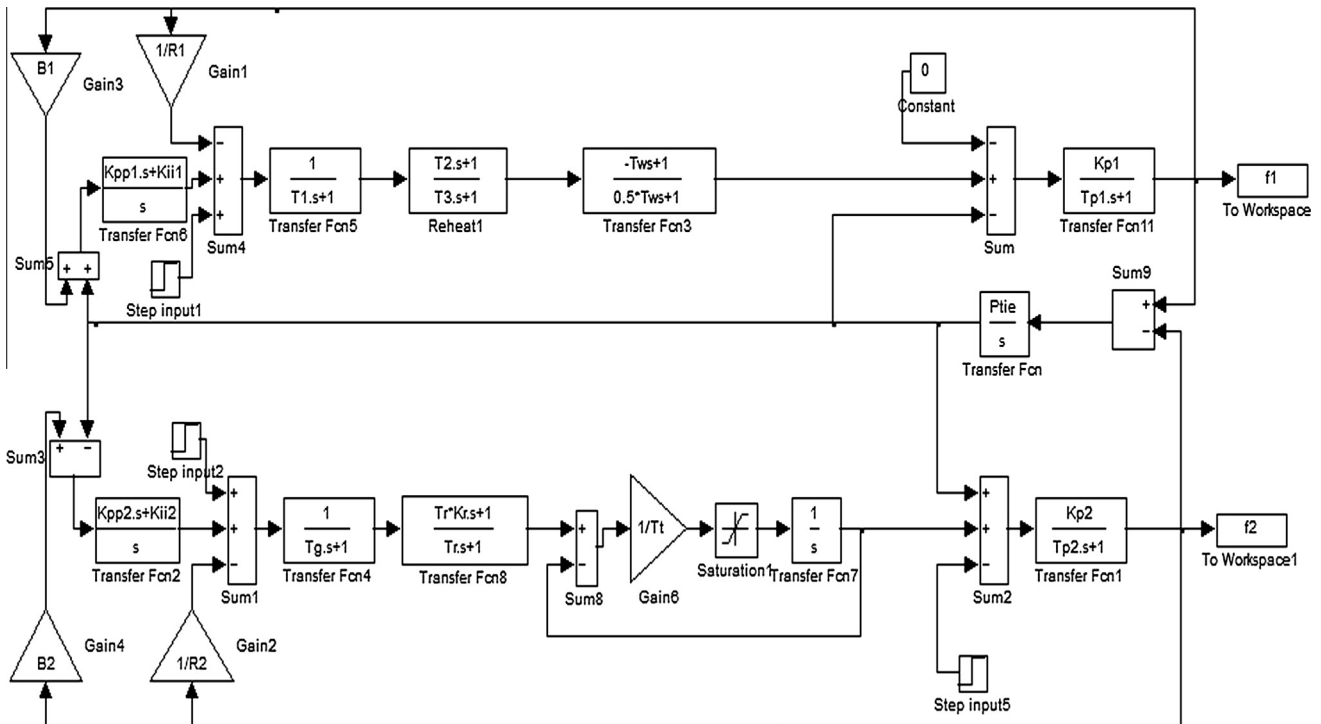

Fig. 1. Block diagram of two area system.

متن کامل مقاله

دریافت فوری ←

ISIArticles

مرجع مقالات تخصصی ایران

- ✓ امکان دانلود نسخه تمام متن مقالات انگلیسی
- ✓ امکان دانلود نسخه ترجمه شده مقالات
- ✓ پذیرش سفارش ترجمه تخصصی
- ✓ امکان جستجو در آرشیو جامعی از صدها موضوع و هزاران مقاله
- ✓ امکان دانلود رایگان ۲ صفحه اول هر مقاله
- ✓ امکان پرداخت اینترنتی با کلیه کارت های عضو شتاب
- ✓ دانلود فوری مقاله پس از پرداخت آنلاین
- ✓ پشتیبانی کامل خرید با بهره مندی از سیستم هوشمند رهگیری سفارشات