

Exergy-topological analysis and optimization of a binary power plant utilizing medium-grade geothermal energy



Deodat Makhanlall*, Fuzhen Zhang, Ruina Xu, Peixue Jiang

Beijing Key Laboratory of CO₂ Utilization and Reduction Technology,
Key Laboratory for Thermal Science and Power Engineering of the Ministry of Education, Department of Thermal Engineering, Tsinghua University,
100084 Beijing, PR China

ARTICLE INFO

Article history:

Received 30 May 2014
Received in revised form
2 August 2014
Accepted 6 September 2014
Available online 16 September 2014

Keywords:

Exergy-topological analysis
Binary power plant
Geothermal energy
Optimization
CyclePad

ABSTRACT

While it is generally accepted that high efficiency conversion of low- and medium-grade heat to electrical power strongly relies on a suitable combination of thermodynamic cycle and working fluid, the selection of suitable operating parameters may be of even more importance. This study shows that medium-grade geothermal heat-to-power conversion in a well-designed secondary regenerative Rankine cycle can achieve a high degree of thermodynamic perfection and exergy efficiency, without the use of high-cost advance powerfluids. The study is carried out by combining a recently developed exergy-topological analysis scheme with CyclePad[®], an open-source cognitive thermodynamic tool. The powerful sensitivity analysis capability of CyclePad[®] is used to determine optimal operating conditions. In addition, application of an extensive exergy-flow diagram, which includes flows in the geothermal production well and cooling cycle, is discussed. A key strategy for improving the thermodynamic efficiency of medium-grade geothermal power plants is also presented.

© 2014 Elsevier Ltd. All rights reserved.

1. Introduction

Low- and medium-grade geothermal heat (<200 °C) is commonly employed for space heating and in domestic hot water supply. By their potential for replacing conventional boilers, such natural thermal resources are likely to play an important role in reducing CO₂ emissions [1]. However, there is also much interest in converting the abundant low- and medium-grade geothermal heat into electrical power. Of key importance for this purpose is the selection of a suitable combination of thermodynamic cycle and working fluid. Several cycles such as the Kaline cycle, the Goswami cycle, and the organic Rankine cycle have been specifically developed for converting low-grade energy into power. The performance of various high density working fluids with low boiling temperature have also been studied extensively [2–5]. However, of even more importance, may be the selection of operating parameters when considering the use of low-grade heat sources in power generating systems. Hence, the objective of this work is to assess

the thermodynamic performance of a conventional power cycle utilizing medium-grade geothermal energy under optimal operating conditions. The study is carried out by combining the exergy-topological analysis scheme of Nikulshin and Wu [6] with CyclePad[®], an open-source cognitive thermodynamic tool developed by Professor Kenneth Forbus at the Northwestern University. The approach significantly reduces computational efforts and is especially suitable for sensitivity analysis. Geothermal heat of 150 °C and 300 kPa, is considered. For converting geothermal energy of this temperature and pressure, a binary power system based on the regenerative Rankine cycle has been proposed [1].

2. Mathematical formulations

2.1. Geothermal power plant model

Fig. 1 depicts the model of the binary geothermal power plant. Geothermal hot water flows through the boiler (I), where the heat absorbed from hot porous rocks within the Earth's interior is transferred to the working fluid of a secondary regenerative Rankine cycle. Steam is taken as the working fluid, and the heating process is assumed to occur at constant pressure. This approach is acceptable as long as the pressure drop due to fluid

* Corresponding author.

E-mail addresses: deodat@mail.tsinghua.edu.cn, makhanlalldeodat@gmail.com, dmakhanlall@hit.edu.cn (D. Makhanlall).

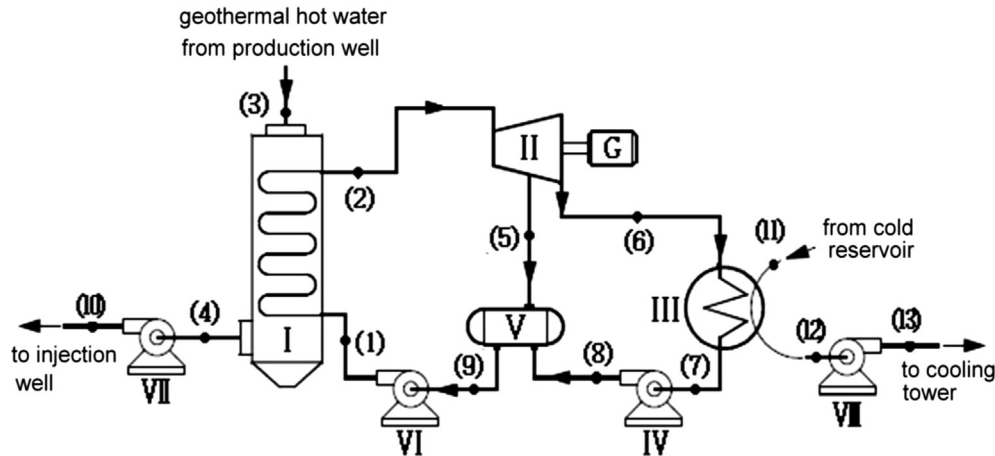

Fig. 1. Binary geothermal power plant (with boiler (I), turbine (II), condenser (III), feed-water heater (V), pumps (IV, VI, VII, VIII), and generator (G)).

friction at the boiler walls is small. The steam is then expanded in a two-staged turbine (II) to produce mechanical shaft work. The turbine efficiency during the high-pressure (HP) first stage and low-pressure (LP) second stage are taken as 90% and 85%, respectively. The expansion process in the turbine is modelled as adiabatic and, in order to prevent damage to the turbine, steam quality is not allowed to drop below 0.9. The assumption of adiabatic expansion is reasonable because the heat transfer surface area of the turbine is relatively small, and the length of time required for the working fluid to pass through the turbine is short. Between turbine stages, some of the steam is extracted for feed-water heating. The rest of the steam is fed to a condenser (III), where heat is removed from the fluid to the surroundings. The cooling process is assumed to occur at constant pressure. Pump (IV) and pump (VI) pumps the saturated fluid through the open-type feed-water heater (regenerative heat exchanger) back

to the boiler (I). The analysis also includes the pumps used in the cycles of the geothermal fluid (pump (VII)) and cooling water (pump (VIII)). Heat loss from pumps is neglected and pump efficiency is assumed 85%. The analysis of each element is further simplified by considering the changes between inlet and outlet kinetic and potential energies to be very small in comparison with the changes in enthalpy.

2.2. Exergy-topological analysis

Analysis of the power plant is based on the exergy-topological methodology introduced by Nikulshin and Wu [6]. This approach combines exergetic analysis with a mathematical method of graphs theory. Step-by-step instructions to apply the exergy-topological methodology are presented in Fig. 2. The preliminary steps of the analysis involve constructing the exergy flow graph from the power plant schematic, and setting up a matrix of incidence. The graph, which is a network of nodes, shows the exergy flows into and out of each element, and allows the exergy flows to be schematically accounted for. The exergy flow graph of the geothermal power plant is shown in Fig. 3. The corresponding matrix of incidence is shown in Table 1, and is readily obtained from the exergy flow graph. The incidence matrix is especially useful when assessing thermodynamic parameters such as the influence coefficient of complex systems [6]. Together, the flow graph and incidence matrix provide a systematic overview of the interconnections between the

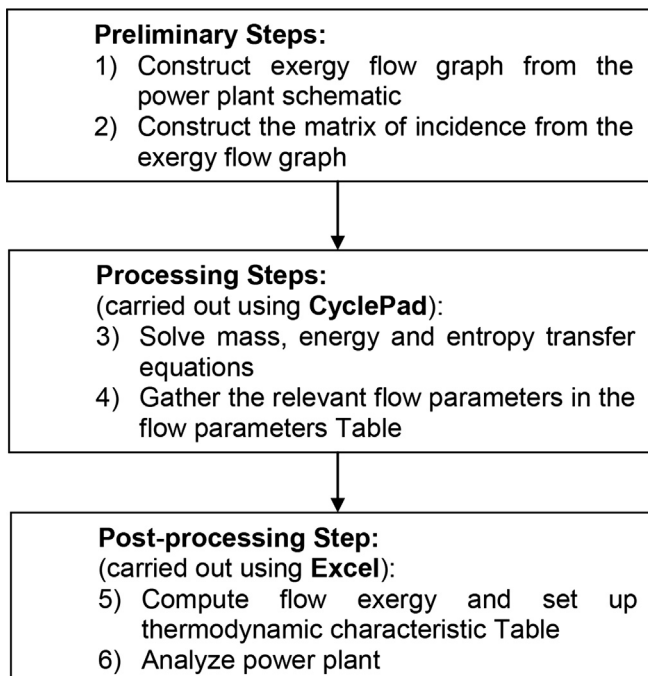

Fig. 2. Exergy-topological methodology step-by-step instructions [7].

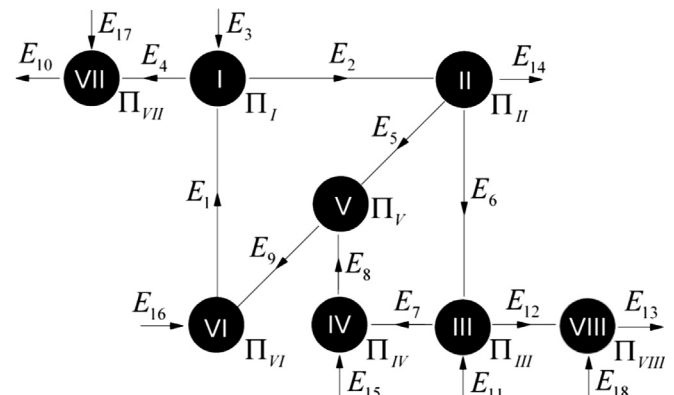

Fig. 3. Exergy flow graph of binary geothermal power plant.

متن کامل مقاله

دریافت فوری ←

ISIArticles

مرجع مقالات تخصصی ایران

- ✓ امکان دانلود نسخه تمام متن مقالات انگلیسی
- ✓ امکان دانلود نسخه ترجمه شده مقالات
- ✓ پذیرش سفارش ترجمه تخصصی
- ✓ امکان جستجو در آرشیو جامعی از صدها موضوع و هزاران مقاله
- ✓ امکان دانلود رایگان ۲ صفحه اول هر مقاله
- ✓ امکان پرداخت اینترنتی با کلیه کارت های عضو شتاب
- ✓ دانلود فوری مقاله پس از پرداخت آنلاین
- ✓ پشتیبانی کامل خرید با بهره مندی از سیستم هوشمند رهگیری سفارشات