

# Early development of an innovative building integrated wind, solar and rain water harvester for urban high rise application

W.T. Chong<sup>a,\*</sup>, A. Fazlizan<sup>a</sup>, S.C. Poh<sup>a</sup>, K.C. Pan<sup>a</sup>, H.W. Ping<sup>b</sup>

<sup>a</sup> Department of Mechanical Engineering, Faculty of Engineering, University of Malaya, 50603 Kuala Lumpur, Malaysia

<sup>b</sup> UMPEDAC, Level 4, Engineering Tower, Faculty of Engineering, University of Malaya, 50603 Kuala Lumpur, Malaysia

## ARTICLE INFO

### Article history:

Received 15 September 2011

Received in revised form

25 November 2011

Accepted 26 November 2011

### Keywords:

On-site renewable energy generation

Power-augmentation-guide-vane

Green architecture

Urban wind energy

Wind–solar–rain water harvester

Vertical axis wind turbine

## ABSTRACT

An innovative 3-in-1 wind–solar hybrid renewable energy and rain water harvester is designed for urban high rise application. A novel power-augmentation-guide-vane (PAGV) that surrounds the Sistan rotor vertical axis wind turbine (VAWT) is introduced to guide and increase the speed of the high altitude free-stream wind for optimum wind energy extraction. The system was also designed to provide optimum surface area and orientation for solar power generation. On the top surface of the PAGV, rain water can be collected, thereby reducing the electrical power required to pump water to the upper levels of the high rise building. To minimize the visual impact, the outer design of the PAGV can be blended into the building architecture. The system is also designed to eliminate the bird-strike problem and the concern on safety, and reduce the vibration. Wind tunnel testing on the scaled down prototype shows that the PAGV improved the starting behavior and increased the rotational speed of the Sistan rotor VAWT by 73.2% at the wind speed of 3 m/s. According to the present study, with the 30 m diameter and 12 m high PAGV integrated system, the estimated annual energy generated and savings is 160 MWh.

© 2011 Elsevier B.V. All rights reserved.

## 1. Introduction

Recently, the negative effects of pollution caused by fossil fuel power generation have urged the importance of developing clean energy generation. Thus, it is beneficial to the society to promote green and sustainable energy usage in our daily lives to overcome the finite character of fossil fuels. Many studies have recognized wind and solar energy as potential sources of free, clean and inexhaustible energy. Energy generation from both solar and wind energy requires no usage of water, thus they would not bring out the environmental concerns, i.e. water crisis problem, compared to energy generation from other sources such as hydro, biomass and nuclear.

Malaysia is situated at the equatorial zone, and experiences low speed winds (doldrums) consisting of Southwest and North-east Monsoons in a year. Most of the areas in mainland experience low (free-stream wind speed,  $V_{\infty} < 4$  m/s for more than 90% of total wind hours) and unsteady wind speeds. As a result, most of the existing wind generators (rated wind speed,  $V_{\text{rated}} = 9\text{--}15$  m/s) are not suitable for Malaysian applications since they are designed for high wind speeds. Based on the study conducted by Chong

[1], wind energy in Malaysia can only be an economically viable generation of electricity for isolated areas far away from the national grid system. Meanwhile; in Europe, due to the decreasing number of economic sites, organizations involved in planning are urged to place wind turbines closer to populated areas [2]. In order to design a wind energy generation system that can be used in urban areas, there are barriers which must be considered such as acoustic pollution, structural issues, safety problems, blade failures, electromagnetic interference and visual pollution [3,4].

There are several possibilities whereby wind energy generation systems can be integrated into urban environments and they can be categorized into three types [5]:

- Siting stand-alone wind turbines in urban locations.
- Retrofitting wind turbines onto existing buildings.
- Full integration of wind turbines together with architectural form.

For the first option, it may encounter constraints of limitation of land in urban area and low wind speed due to other existing high rise buildings. It may also give rise to public concern over safety, issues of noise and visual impact. For the second approach, small-scale turbines are easily viable as a building retrofit solution and these micro-wind turbines in various types are commercially available [6]. The government of UK provided attractive schemes which

\* Corresponding author. Tel.: +60 12 7235038; fax: +60 37 9675317.

E-mail addresses: [chong\\_wentong@um.edu.my](mailto:chong_wentong@um.edu.my), [chong\\_wentong@yahoo.com](mailto:chong_wentong@yahoo.com) (W.T. Chong).

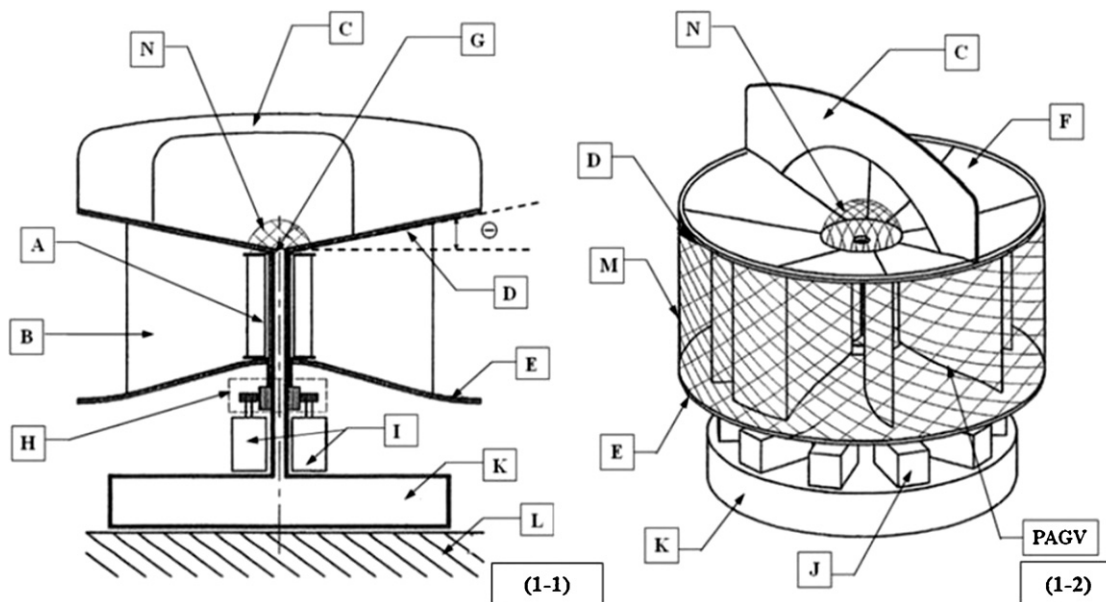

Fig. 1. General arrangement of the wind-solar hybrid energy system with rain water collection feature – (1-1) side sectional view; (1-2) perspective view [17].

accounted for approximately 17% of state grant aid to encourage the application of micro-wind turbines in urban area [7]. However, such small-scale wind turbines for building integration may not always be aesthetically pleasing and also hazardous due to turbine blades failures occurring. For retrofitting wind turbine into existing building, there is an obvious difference in visual impact between the conventional wind turbine and the one that is specially designed for urban area as illustrated by Sharpe and Proven [8]. The third strategy of a fully integrated solution involves a well-defined construction plan and huge capital. A matrix of generic options for integrating wind turbines into the building was developed during the initial phase of the project [5]. It might seem fascinating from both the architectural and aerodynamics point of view. However, the issues of safety, noise, vibration and visual impact should not be underestimated.

## 2. Building integrated wind turbines

Building integrated wind turbines are gaining more attention for urban on-site clean energy generation. The concept of on-site renewable energy generation is to extract energy from renewable sources close to the populated area where the energy is required [9]. The factors that influence the decision to build a building integrated wind turbines are the positioning (height above roof ridge and position relative to the prevailing wind direction), the urban terrain roughness and the adjacent buildings that can cause wind shadow [10].

The large-scale building integrated wind turbines have been demonstrated in some countries. These buildings have been established as iconic buildings. The first large-scale integration of wind turbines with a building is the Bahrain World Trade Center. This 240 m high building harmoniously integrates building augmented design with three horizontal axis wind turbines of 29 m diameter [11]. The Strata Tower in London was built to incorporate wind turbines within its structure. The three wind turbines at the top of the building are rated at 19 kW each and are anticipated to produce 8% of electricity needed by the building [12]. In Guangzhou, China; the Pearl River Tower was designed to harness the energy from solar and wind to sustain the building. The wind is funneled down from the vertical face of the tower toward a series of wind turbines for energy generation [13].

With further consideration of building and architectural integration, Müller et al. [14] has proposed and architecturally demonstrated a wind energy converter with a cylindrical form to facilitate current building design. Grant et al. [15] also reported and concluded that ducted wind turbines which are attached to the building roof have a significant potential for retrofitting into a building with small concern of visual impact. A concept and early development of the wind turbine called Crossflex utilized an existing Darrieus turbine concept, but it was applied in a novel form for building integration [8].

The demonstrative study for the wind and solar power hybrid system from Ashikaga Institute of Technology in Japan shows that the generated power by photovoltaic cells is abundant in the summer season and that by wind powered generator increases from autumn to winter. Thus, in the Ashikaga area, the utilization of wind energy is not promising in the summer season compared to solar energy. Consequently, the stable power output could be expected by the above-mentioned seasonal complementary relationship between the solar and wind energy after 1-year operation of the system [16].

As a result, an innovative design of power-augmentation-guide-vane (PAGV) to integrate several green elements (urban wind turbine, solar array for electricity and hot water, and rain water collector) is introduced [17]. It is compact and can be built on the top (or between upper levels) of high rise buildings or structures in order to provide on-site green power to the building. Besides, this system can be used in remote and urban areas of both low wind speed and high wind speed regions. This system also fully utilizes the advantages of Malaysian climate, i.e. high solar radiation and high rainfall for green energy generation and free water supply. Consolidation of the hybrid system as part of building architecture without negative visual impact definitely overcomes the barriers of implementing building integrated renewable energy system.

## 3. Novel design of the wind, solar and rain water harvester

### 3.1. General arrangement and working principle of the design

The patented design of this wind, solar and rain water harvester integrates and optimizes several green technologies; including urban wind turbine, solar array and rain water collector [17]. Fig. 1

متن کامل مقاله

دریافت فوری ←

**ISI**Articles

مرجع مقالات تخصصی ایران

- ✓ امکان دانلود نسخه تمام متن مقالات انگلیسی
- ✓ امکان دانلود نسخه ترجمه شده مقالات
- ✓ پذیرش سفارش ترجمه تخصصی
- ✓ امکان جستجو در آرشیو جامعی از صدها موضوع و هزاران مقاله
- ✓ امکان دانلود رایگان ۲ صفحه اول هر مقاله
- ✓ امکان پرداخت اینترنتی با کلیه کارت های عضو شتاب
- ✓ دانلود فوری مقاله پس از پرداخت آنلاین
- ✓ پشتیبانی کامل خرید با بهره مندی از سیستم هوشمند رهگیری سفارشات