

Operations management of a packaging plant in the fruit industry

A.M. Blanco^a, G. Masini^{a,b}, N. Petracci^a, J.A. Bandoni^{a,*}

^a *Planta Piloto de Ingeniería Química, PLAPIQUI (UNS-CONICET), Camino La Carrindanga, Km. 7, 8000 Bahía Blanca, Argentina*

^b *Department of Mechanical Engineering, Engineering Faculty, Universidad Nacional del Comahue Buenos Aires 14000, (8300) Neuquén, Argentina*

Received 8 October 2003; received in revised form 8 March 2004; accepted 12 May 2004

Available online 12 January 2005

Abstract

The production of fresh fruit (apples and pears) and concentrated juice is one of the major regional economic activities of Argentina, which has traditionally been one of the world's main fresh fruit and concentrated juice producers. Due to market reasons, there is a strong need to count with reliable decision tools to manage the whole business. In order to tackle this problem, advantages can be taken from developments on formulations of planning and scheduling models. In this work, a realistic planning model of a packaging plant, the most important instance within the fresh fruit supply-chain industry from a tactical point of view, is developed. The model can be applied to estimate the fruit processing capacity of the facility in order to establish future sales policies.

© 2004 Elsevier Ltd. All rights reserved.

Keywords: Fruit industry; Packing plant; Operations management

1. Introduction

The production of fresh pip fruit (apples and pears) and concentrated juice is one of the major regional economic activities of Argentina. The “Alto Valle de Rio Negro y Neuquén” area of Argentina (AVRNN), located across two states southwest of the country, is the region where apples and pears are grown.

During the 90s, fruit companies made important capital investments on new machinery for efficiency improvement. More recently, due to new worldwide competitors from South West Asia, local economic problems and volatile international markets, companies were compelled to improve even more their competitiveness to keep on business.

There are a few large companies that operate along the complete fruit industry supply chain (FISC), and concentrate the largest part of the business in the

AVRNN region. A typical FISC of one of these companies involves one or more packaging and concentrated juice plants. Raw material for these plants can be supplied from own and/or third party farms. Final customers involve overseas, regional and local markets. Previous work (Masini, Petracci, & Bandoni, 2003) has addressed the Argentinean FISC planning problem.

Packaging plants (PP) represent the core of the FISC from a tactical point of view. At a PP, after raw material reception a decision has to be made whether the fruit is sent to cold storage for later processing or directly to the processing line. The processing line involves several steps consisting in washing, manual and automatic classification (by size, color, external aspect, etc.), waxing (if required), and packaging in different ways depending on customer preferences.

In the last decade there has been an increasing effort in developing and applying planning models in different instances of the food industry and in particular in the fruit industry. Mathematical programming planning models have been proposed for example for pip fruit orchard replacement (Kearney, 1994), to address the

* Corresponding author. Tel.: +54 91 4861 700; fax: +54 91 4861 600.

E-mail address: abandoni@plapiqui.edu.ar (J.A. Bandoni).

biophysical growth of apple plants (Hester & Cacho, 2003) and to fruit farm activities scheduling (Vitoriano, Ortuño, Recio, Rubio, & Alonso-Ayuso, 2003). According to the authors' knowledge, however, no contributions have addressed the operations management issues of PPs as described. Close related work is Broekmeulen (1998), where a tactical decision model for distribution centers for vegetables and fruits has been proposed. The main objective of that model is to provide an optimal assignment of the different perishables to the diverse storage zones within the center in order to minimize the so-called keeping quality loss.

It is the purpose of this contribution to present a detailed planning model of the operation of a PP, which includes its storage and processing activities, as described for the FISC. The model is intended to operate in a *profit mode*, this is to estimate the amount of products that the installed capacity can process provided a historical profile of fruit income. In such a mode of operation, the proposed model is considered to be a valuable tool in order to establish future sales policies.

2. Packaging plant description

The following activities take place in a typical PP of the FISC in the AVRNN area. The flow diagram for a single processing line PP is roughly sketched in Fig. 1.

1. Warm fresh fruit from woods is fed to the processing line (X_1), floating in a stream of water treated with fungicides. These fruits receive a treatment with pesticides, in a module for fruit washing called Drencher (DR), where dirt and fungus spores are eliminated.
2. After the Drenching stage, a decision has to be made whether the fruit is processed (X_3) or cold stored for further processing (X_2). In general non-processed fruit storage (NPFS) is undesirable due to economic reasons but it could be necessary if the income of fruit exceeds the processing capacity of the line.

3. The fruit enters to the pre-classification (PC) stage (X_5) where non-tradable fruit is separated for juice production (W_1). Part of the fruit entering PC can come from NPFS (X_4) if required.
4. Pre-classified fruit (X_6) proceeds to the washing module (WA), where it is washed with water containing special chemical products. The fruit is then rinsed and dried before further processing.
5. If required, washed fruit enter the waxing module (WX) where it is sprayed with wax, which is further dried with hot air. To process fruit without wax, WX is simply by-passed.
6. The fruit (stream X_7) enters the quality classification sector (QC) where it is separated in several categories, according to the degree of defects or damage that the pieces present (X_8). Some waste is also produced at this stage (W_2).
7. Once the fruit has been classified by quality, it is further classified by size or weight (depending on the available technology) in several types at the gauge classification module (GC) (stream X_9). Some waste is also produced at this stage (W_3).
8. Each sized or weighted fruit enters to the packaging section (PK) where it is packed according to the characteristics of the container specified by the client. There is a variety of crate possibilities which determines an amount of final products (stream X_{10}).
9. Containers of the same type are stowed in pallets according to their sizes in refrigerating chambers (Processed Fruit Storage, PFS).
10. Finally, processed fruit is sent to port cold storage facilities if overseas products are involved, or dispatched by trucks to regional and local markets (X_{11}).

In the following a brief description of several important issues are discussed to present a more complete picture of the activity.

2.1. Fruit income

During the harvest a regular income of the different fruit varieties occurs according to the particular harvest period. Based on historical records, an income profile in terms of amount, waste, quality and gauge for each fruit variety can be established. The parameters of such a profile are stochastic in nature. Average and standard deviation values for such parameters are reported in Tables 1–4. By means of Monte Carlo simulation, deterministic fruit income profile scenarios are generated to feed the proposed deterministic planning model.

2.2. Waste

A fraction of the income fruit is non-tradable due to esthetic issues (damage, imperfections, size, etc.). Such a

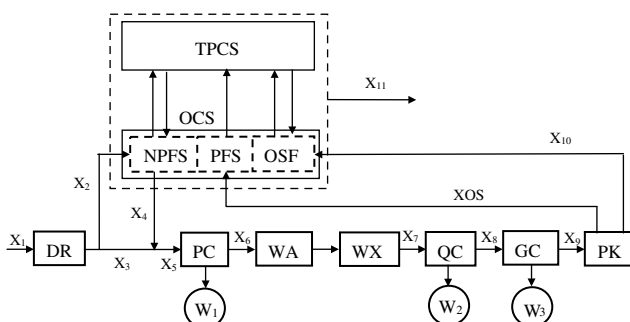

Fig. 1. Scheme of a packaging plant.

متن کامل مقاله

دریافت فوری ←

ISIArticles

مرجع مقالات تخصصی ایران

- ✓ امکان دانلود نسخه تمام متن مقالات انگلیسی
- ✓ امکان دانلود نسخه ترجمه شده مقالات
- ✓ پذیرش سفارش ترجمه تخصصی
- ✓ امکان جستجو در آرشیو جامعی از صدها موضوع و هزاران مقاله
- ✓ امکان دانلود رایگان ۲ صفحه اول هر مقاله
- ✓ امکان پرداخت اینترنتی با کلیه کارت های عضو شتاب
- ✓ دانلود فوری مقاله پس از پرداخت آنلاین
- ✓ پشتیبانی کامل خرید با بهره مندی از سیستم هوشمند رهگیری سفارشات