



Effects of component polytropic efficiencies on the dimensions of monophasic ejectors

Payam Haghparast^a, Mikhail V. Sorin^{a,*}, Hakim Nesreddine^b

^a Mechanical Engineering Department, Université de Sherbrooke, Sherbrooke, QC J1K 2R1, Canada

^b Hydro-Québec, 600 Rue de la montagne, Shawinigan, QC G9N 7N5, Canada



ARTICLE INFO

Keywords:

1D model
Polytropic efficiency
Ejector dimensions
Parametric study

ABSTRACT

An inappropriate choice of isentropic efficiencies for the sizing of the component parts of monophasic ejectors is one of the greatest sources of error in their design. The present study shows that the replacement of isentropic efficiencies with polytropic efficiencies within 1D ejector models provides more accurate results. Polytropic efficiencies access more precisely the effects of the pressure ratio variation on the irreversibilities of the acceleration and deceleration processes. It is demonstrated that the deviation in the constant area duct length, calculated by using an isentropic efficiency from the real length is three times greater than the one calculated by using a polytropic efficiency. The polytropic efficiencies are extracted from the CFD modeling of two types of ejectors, a constant area mixing (CAM) ejector and a constant pressure mixing (CPM) ejector. A 1D thermodynamic model for CAM and CPM ejectors, based on the polytropic efficiency concept, is proposed and validated against experimental data. Parametric studies based on this model were completed. They reveal that the variation in polytropic efficiency of the primary nozzle has the most important impact on the constant area duct length. New empirical correlations to estimate the polytropic efficiencies are also provided.

1. Introduction

An Ejector is a simple, reliable and low-cost device to produce vacuum by accelerating a gas, vapor or liquid in a nozzle. Ejectors employ liquid or gas as a motive fluid without using any moving parts. Typical ejector construction includes four distinct parts: a convergent–divergent nozzle, a suction chamber attached to a constant area duct and a diffuser (Fig. 3).

Ejectors are considered as an alternative to compressors in refrigeration systems due to no source of power is required other than the motive gas and they are easy to install, operate and maintain. The layout of an ejector refrigeration cycle is shown in Fig. 1.

Research studies on the ejector as a favorable device is on the increase since the 1950s to date. The performance of ejectors has been carefully considered theoretically and experimentally. Most Researchers believe that it is essential to enhance the performance of ejectors in order to make them economically more attractive. For this reason, numerous investigations on optimizing the ejector performance have been carried out.

Among these studies, comparing different refrigerants in order to achieve an appropriate working fluid under varying operating conditions and effects of the geometry on the ejector performance are

considerably investigated experimentally and numerically.

The effects of different refrigerants on the ejector efficiency in the refrigeration systems are studied by [1–3]. Some researchers have investigated the effect of ejector geometry on its performance, such as nozzle exit location, mixing chamber/nozzle area ratio, and nozzle design. Banasiak et al. [4] examined different ejector configurations in order to achieve optimum ejector geometry. They used various lengths and diameters of the mixing duct and various angles of divergence for the diffuser. Cizungu et al. [5] and Tang et al. [6] optimized the ejector geometry to achieve maximum values for either the entrainment ratio or the pressure ratio. Vereda et al. [7], Elbel [8] and Omidvar et al. [9] experimentally studied different ejector dimensions, such as the sizing of the motive nozzle, the diffuser and nozzle exit position. Nakagawa et al. [10] experimentally analyzed the effect of the mixer length on ejector system performance. A review of recent developments in advanced ejector technology can be found in [11,12].

Researchers always make assumptions for theoretical analyses of the ejectors. One of the most important assumptions is assuming the appropriate component efficiencies. Some consider constant isentropic efficiencies at various parts along the ejector, including the primary nozzle, secondary nozzle, and diffuser in order to take into account the irreversibilities. Tyagi and Murty [13] assumed these constants

* Corresponding author.

E-mail address: Mikhail.V.Sorin@USherbrooke.ca (M.V. Sorin).

Nomenclature		Subscripts	
A	cross section area (mm ²)	cp	critical point
D	diameter (mm)	d	downstream of shock
F	force (N)	D	diffuser
f	friction coefficient (-)	e	exit
h	specific enthalpy (kJ kg ⁻¹)	f	friction
L	length (m)	is	isentropic
\dot{m}	mass flow rate (kg s ⁻¹)	mix	mixing
Ma	Mach number	out	outlet
P	pressure (kPa)	pol	polytropic
PR	pressure ratio = P_1/P_6 (-)	p	primary nozzle
s	specific entropy (kJ kg ⁻¹ K ⁻¹)	s	secondary nozzle
T	temperature (K)	th	ejector throat
Therm	thermodynamic	tot	total
V	velocity (m s ⁻¹)	u	upstream of shock
v	specific volume (m ³ kg ⁻¹)	1	exit of ejector
X	position of nozzle exit (mm)	4	primary inlet
<i>Greek symbols</i>		6	secondary inlet
ϵ	wall roughness (mm)	7	nozzle exit
η	efficiency	8	inlet of diffuser
θ	half-angle (deg)	<i>Acronyms</i>	
ω	entrainment ratio = \dot{m}_s/\dot{m}_p (-)	CAM	constant area mixing
ρ	density (kg m ⁻³)	CPM	constant pressure mixing

arbitrarily. Aly et al. [14] and Cizungu et al. [5] chose values from the literature. Some researchers experimentally determined the constants [15–17]. Varga et al. [18] and Zhang et al. [19] extracted values from a CFD model. Grazzini and Rocchetti [20] used a “trial and error” approach by comparing the solution from a 1D model to CFD results.

In all of the previously referenced 1D models, the constant isentropic efficiencies were used. Recently Galanis and Sorin [21] introduced the concept of the polytropic efficiency for the ejectors. The polytropic efficiencies are used extensively in the design and analysis of compressors and turbines [22] but has only recently been applied to the study of ejectors [23–25]. However, the authors did not present a proof that the application of the polytropic efficiency is advantageous compared to the isentropic efficiency. The polytropic efficiency is defined as the isentropic efficiency of an elemental process (Fig. 2). It takes into account the elemental pressure ratio and the irreversibilities occurring during the acceleration and deceleration processes, unlike isentropic efficiency.

The number of papers dedicated to the thermodynamic modeling of the ejectors is considerable. This research paper has the following novelty and originality items:

- (1) The proposed 1D model is more realistic than previous 1D models due to the application of the polytropic (or elemental) efficiency conception. In this case, the 1D model is able to consider the effects

of the pressure ratio on the entropy increase during the irreversible acceleration and deceleration processes, unlike previous models, which use isentropic (or overall) efficiencies for this purpose.

- (2) Real values of the polytropic efficiencies are calculated by CFD models for the first time. In this case, the 1D model is able to evaluate the ejector dimensions and flow properties more accurately.
- (3) A comprehensive comparison between all dimensions obtained by the 1D model based on isentropic and polytropic efficiencies is carried out against experimental data. In order to make a robust comparison, two separate cases of experimental ejector data are considered, namely a constant area mixing (CAM) ejector and a constant pressure mixing (CPM) ejector, with different known geometries, working fluids (R245fa, R141b), and operating conditions.
- (4) The improved 1D model is able to evaluate all diameters and lengths of both types of ejectors, in particular the length of the constant area duct (L_4). All Previous models only determined some dimensions, without including an explicit method for the calculation of the constant area duct length.
- (5) A parametric study of the main parameters is performed to improve the ejector sizing by using the validated 1D model. The effects of the following parameters on all ejector dimensions are investigated for a base case: the primary and secondary inlet pressures, the diffuser exit back pressure, the component polytropic efficiencies, and the mass flow rates.
- (6) Empirical correlations are established to estimate the polytropic efficiencies and to demonstrate the interaction between ejector parameters.

2. Ejector operation and geometry

In this study, two different types of the ejectors are considered, based on the design nozzle exit position, namely constant area mixing (CAM) and constant pressure mixing (CPM).

In constant area mixing ejector, the nozzle exit is located within the constant area duct as the mixing of the primary and secondary streams

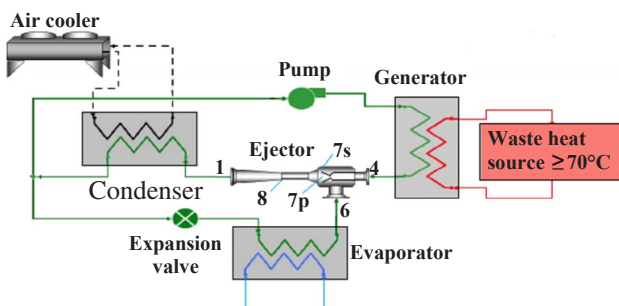

Fig. 1. The schematic diagram of the ejector refrigeration system.

متن کامل مقاله

دریافت فوری ←

ISIArticles

مرجع مقالات تخصصی ایران

- ✓ امکان دانلود نسخه تمام متن مقالات انگلیسی
- ✓ امکان دانلود نسخه ترجمه شده مقالات
- ✓ پذیرش سفارش ترجمه تخصصی
- ✓ امکان جستجو در آرشیو جامعی از صدها موضوع و هزاران مقاله
- ✓ امکان دانلود رایگان ۲ صفحه اول هر مقاله
- ✓ امکان پرداخت اینترنتی با کلیه کارت های عضو شتاب
- ✓ دانلود فوری مقاله پس از پرداخت آنلاین
- ✓ پشتیبانی کامل خرید با بهره مندی از سیستم هوشمند رهگیری سفارشات