

7th International Conference on Silicon Photovoltaics, SiliconPV 2017

## Impact of contacting geometries on measured fill factors

Christian N. Kruse<sup>a,\*</sup>, Martin Wolf<sup>a</sup>, Carsten Schinke<sup>a,b</sup>, David Hinken<sup>a</sup>, Rolf Brendel<sup>a,b</sup>,  
Karsten Bothe<sup>a</sup>

<sup>a</sup> Institute for Solar Energy Research Hamelin (ISFH), Am Ohrberg 1, Emmerthal 31860, Germany

<sup>b</sup> Institute for Solid State Physics, Leibniz Universität Hannover, Appelstraße 2, 30167 Hannover, Germany

---

### Abstract

The fill factor determined from a measured current-voltage characteristic of a bare solar cell depends on the number and positions of the electrical contacting probes. Nine different geometries for contacting the front side busbars are used to measure the current-voltage (I-V) characteristics of a 5 busbar industrial-type passivated emitter and rear totally diffused (PERT) solar cell under standard testing conditions. The fill factors of the measured I-V characteristics vary from 78.5 %<sub>abs</sub> to 80.6 %<sub>abs</sub>. We further measure the contacting resistance of 3 different contacting probes to estimate the sensitivity of measurements with different contacting geometries on random resistance variations. The contacting resistance is 60 mΩ for nine-point probes and 80 mΩ for four- and single-point probes. We determine the magnitude of contacting resistance variations from measurements at different probe positions to be ±30 mΩ. Using this variation, we perform numerical simulations and find a larger sensitivity on random resistance variations for tandem- (pairs of current- and sense probes) compared to triplet (one sense- between two current probes) configurations. The corresponding fill factor deviation is approximately 0.1%<sub>abs</sub> for tandem configurations when the contacting resistances of up to two current probes are altered. The sensitivity for triplet configurations is negligible.

© 2017 The Authors. Published by Elsevier Ltd.

Peer review by the scientific conference committee of SiliconPV 2017 under responsibility of PSE AG.

*Keywords:* Characterization of PV; Current-voltage characteristics; Fill Factor

---

---

\* Corresponding author. Tel.: +49-5151-999-632; fax: +49-5151-999-400.  
E-mail address: [c.kruse@isfh.de](mailto:c.kruse@isfh.de)

## 1. Introduction

The measurement of the current-voltage (I-V) characteristic is essential for classifying solar cells. A variety of measurement setups is commercially available for this purpose. Comparing measurement results obtained with different setups is not trivial, as the setups may differ in terms of illumination conditions, temperature control and the electrical contacting of the cell. This paper focuses on the impact of different geometries for contacting the front side of a solar cell on the fill factor (FF) of measured I-V characteristics. The front side of a solar cell is commonly contacted in a four wire configuration with contacting probes mounted in a narrow bar to minimize shading. The number and positioning of the contacting probes along the bar can be very different between individual measurement setups. One possibility to contact a solar cell for an I-V measurement is to place the contacting probes to reflect the module integration of the solar cell which is, for example, suggested in [1], [2]. However, the module integration of cells can differ and measurement results obtained with this contacting approach cannot be easily compared for different measurement setups. Another approach is to measure the cell such that the results are comparable across different setups. To achieve this comparability the contacting probes can be placed such that the busbar (BB) resistance is neglected [3]–[5]. In this work we measure the I-V characteristics of a 5 BB solar cell using 9 different contacting geometries in order to estimate the implied systematic deviations between measurements with different contacting geometries. We further measure the contacting resistance of different test probes and analyze the differences between tandem and triplet configurations in terms of their sensitivity on random variations of the contacting resistance using numerical device simulations.

## 2. Contacting geometries

### 2.1. Variable contacting bar

In order to measure I-V curves of the same solar cell with a variety of different contacting geometries we use a freely configurable contacting bar manufactured by pv-tools [6] which is shown in figure 1. This contacting bar features two low-resistivity conducting paths which are insulated from each other. The first serves as current conducting path and the second for voltage sensing. The contacting probes can be mounted in a total of 31 slots and then connected to either of the conducting paths using a jumper cable. The distance between the slots is 5 mm. The connection to the conducting path for voltage sensing is realized over a 500  $\Omega$  resistor to minimize current flow over the conduction path. The low resistivity of the current conduction path ensures that all current contacting probes are at the same potential.

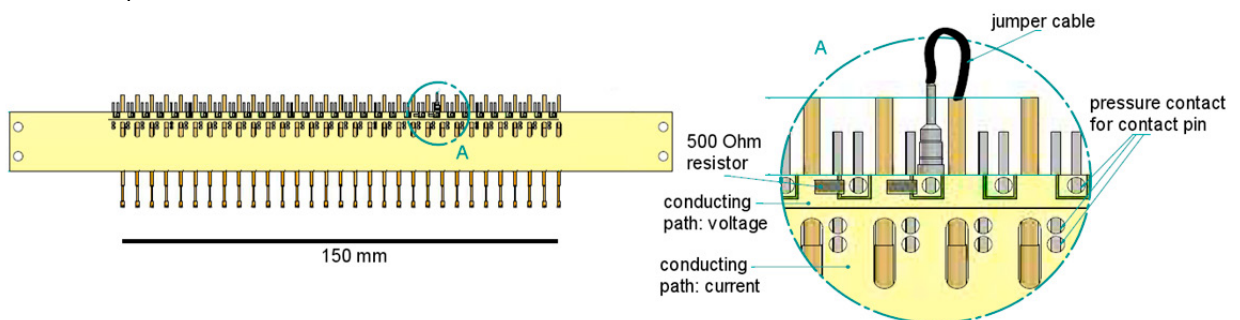

Fig. 1. Variable contacting bar with a total of 31 removable test probes. Each of these test probes can be used as a sense or a current probe by connecting the jumper cable to the respective conducting path.

### 2.2. Measuring the busbar resistance

The deviations between measurements with different contacting geometries arise from potential variations along the BBs of the solar cell. The main impact on this potential variation rises from a nonzero BB resistance and the

متن کامل مقاله

دریافت فوری ←

**ISI**Articles

مرجع مقالات تخصصی ایران

- ✓ امکان دانلود نسخه تمام متن مقالات انگلیسی
- ✓ امکان دانلود نسخه ترجمه شده مقالات
- ✓ پذیرش سفارش ترجمه تخصصی
- ✓ امکان جستجو در آرشیو جامعی از صدها موضوع و هزاران مقاله
- ✓ امکان دانلود رایگان ۲ صفحه اول هر مقاله
- ✓ امکان پرداخت اینترنتی با کلیه کارت های عضو شتاب
- ✓ دانلود فوری مقاله پس از پرداخت آنلاین
- ✓ پشتیبانی کامل خرید با بهره مندی از سیستم هوشمند رهگیری سفارشات