



Dynamic energy, exergy and market modeling of a High Temperature Heat and Power Storage System



A. Arabkoohsar^{*}, G.B. Andresen

Department of Engineering, Aarhus University, 8000 Aarhus, Denmark

ARTICLE INFO

Article history:

Received 29 November 2016

Received in revised form

3 March 2017

Accepted 15 March 2017

Keywords:

Smart energy
Dynamic modeling
Energy storage
District heating
Wind energy
Energy market

ABSTRACT

A novel energy storage system that produces both electricity and heat at high efficiencies and takes advantage of a high temperature hot rock cavern thermal energy storage was recently introduced and designed. This study aims at evaluating the performance of the system in terms of energy and exergy efficiencies under realistic operational conditions where the storage supports a number of wind turbines over a long period. The potential value creation of the energy storage system in the local electricity and heat markets is also assessed. The Western part of Denmark with its high number of wind turbine plants and flexible electricity and heat markets have been chosen for the case study of this work. Having both forecasted and realized wind power generation as well as energy prices for the recent years, the system is designed with rigor and a smart bid strategy for the power plant equipped with the energy storage unit for day-ahead and intra-day markets is determined. The results show that the system is able to compensate the fluctuations of wind power plants, and present high annual overall energy and electricity efficiencies of 80.2% and 31.4% and exergy efficiency of 56.1%.

© 2017 Elsevier Ltd. All rights reserved.

1. Introduction

The wind-solar-biomass mix in the electricity and heat sectors is a corner stone in the planned Danish transition to CO₂ neutral energy production by 2035 [1]. However, serious problems must be addressed for the mix to be successful. Some of these are the topic of the recent report “Smart Energy - hovedrapport” by the Danish TSO (Transmission System Operator) Energinet.dk. Here, special attention is brought to flexible demand and the large and costly need for peak production units for the relatively few hours where wind and solar generations are low while the demand remains high. As a consequence, it is estimated that the total socio-economical value of flexible electricity demand in Denmark will increase from current (low) values to about 100 million Euro per year by 2035. The report points out that increased coupling between the energy sectors, i.e. the smart energy concept [2], is the most cost effective instrument to realize the required flexibility. To this end, several well-understood technologies are explored. Most noticeably these include heat pumps, electric boilers and electrical vehicles.

In the present paper, a new innovative utility scale energy conversion and production technology that directly addresses the shortcomings of the current smart energy technologies mentioned above is studied. To this end, the relevant case of an integrated electricity and heating system of Aarhus city embedded in the electricity grid of Western Denmark has been selected. The new technology is a HTHPSS (High Temperature Heat and Power Storage System) that have been designed specifically to accommodate the increased amounts of variable power generation from VRES (Variable Renewable Energy Sources). The defining features of the storage solution is a very high energy efficiency, low-cost for large-scale installations, environmental friendliness, and the ability to support both power and district heating grids at time scales ranging from sub-seconds (primary reserve) to several days, thus allowing e.g. energy trading, forecast error hedging and peak load support. In addition, it does not require special geological features such as those pumped hydro and CAES (compressed air energy storage) do. The study presented here, includes a dynamic market simulation that allows realistic energy and exergy efficiencies as well as electricity and heat market values to be assessed.

The novelty of the paper lies in the detailed assessment of the new smart energy technology HTHPSS that addresses the typical shortcomings of previously explored technologies, in particular, the need of economically attractive up-wards reserve capacity in the

^{*} Corresponding author.

E-mail address: mani.koohsar@yahoo.com (A. Arabkoohsar).

power market. Traditional electricity to heat conversion technologies, such as boilers and heat pumps, can only provide this service by reducing their load on the system whereas HTHPSS can actively produce power from stored heat in a way similar to that of CSP (concentrated solar power).

1.1. Wind energy and energy storage

The fast increase in energy demand along with environmental awareness over the recent years has speeded up the development of renewable energy resource energy production systems in the global scenario [3]. Among all type of renewable energy resources, wind power has emerged as the biggest source in the world with a large technical and economic potential to provide renewable energy. However, wind power is inherently intermittent and hence, it causes power fluctuation issues and challenge for grid stability. Energy storage provides a direct solution to stabilize the power output of the wind turbine (and other unstable power production units). In fact, energy storage can guarantee offsetting the supplied energy fluctuations and energy availability at the time of peak demand, failure in the system or low energy quality in the grid [4]. These are all why considerable attention is being paid to find efficient ways of storing energy to achieve maximum utilization. As a result of these efforts, various storage technologies have emerged so far [5]. These technologies may be classified as mechanical, thermal and electrochemical energy storage systems. The use of battery (electrochemical), as the most widely used type of storage system, is very expensive and not practical for large energy quantities [6]. By far, pumped hydro and compressed air energy storage have been the only suitable systems for large-scale energy storage applications, though each of these systems has its own drawbacks, i.e. huge capital cost and dependence on topographical conditions for pumped hydro [7] and, special geological site need and not fully developed knowledge for compressed air energy storage system [8]. In a recent study, Arabkoohsar and Andresen [9] introduced HTHPSS for large-scale applications, capable of producing both heat and electricity in high efficiency. Fig. 1 illustrates the schematic of this system. The system is most appropriate for the locations with both heat and electricity demand.

As seen in the figure, there is a thermal energy storage system (hot rock cavern with air as intermediate fluid) initially charged to a temperature of 900 K by electrical coils supported by e.g. surplus power produced by wind turbines. Hereafter, the system may be subject to charging or discharging processes. In charging process, surplus power is applied for heating the cavern up to a maximum temperature of 950 K. In discharging steps, the turbine set starts workings and actuates the multistage compressor set as well as the electricity generator. The intake air by the compressors first passes

through intercooler heat exchangers to cool the compressed air down and provide hot water for district heating purposes. Then, it is warmed up before each stage of expansion through heating heat exchangers supported by hot air coming out from the hot storage cavern. Note that this system has been designed with rigor and comprehensive information about this system and its operational details may be found in Ref. [9].

In this work, the performance of HTHPSS is assessed in terms of energy, exergy and economic performance under dynamic practical input energy, energy demand and power and heat prices. For this objective, a comprehensive mathematical model of the system is presented; the system is designed considering the dynamic operational conditions and a smart strategy for bidding in the electricity markets of the host wind turbine farm as well as the local heat market. The schematic of the combined wind turbine and storage system configuration is given in Fig. 2. According to the figure, the

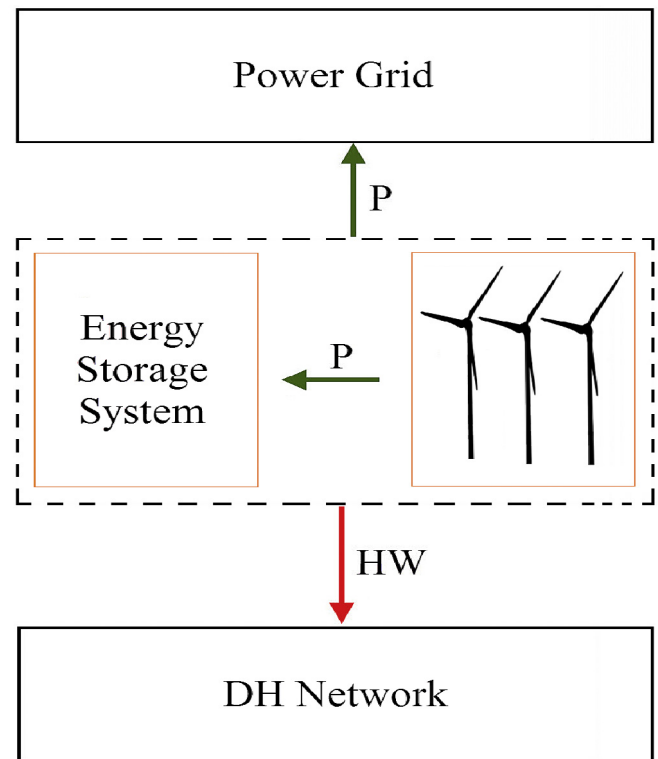

Fig. 2. Schematic drawing of the studied system configuration; DH: district heating, HW: hot water.

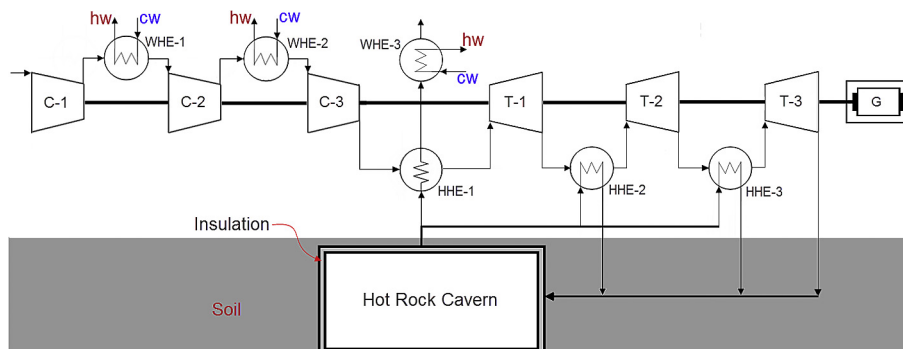

Fig. 1. Schematic of the proposed energy storage system; C: compressor, WHE: water heat exchanger, HHE: heating heat exchanger, T: Turbine, G: electricity generator, cw: cold water, hw: how water.

متن کامل مقاله

دریافت فوری ←

ISIArticles

مرجع مقالات تخصصی ایران

- ✓ امکان دانلود نسخه تمام متن مقالات انگلیسی
- ✓ امکان دانلود نسخه ترجمه شده مقالات
- ✓ پذیرش سفارش ترجمه تخصصی
- ✓ امکان جستجو در آرشیو جامعی از صدها موضوع و هزاران مقاله
- ✓ امکان دانلود رایگان ۲ صفحه اول هر مقاله
- ✓ امکان پرداخت اینترنتی با کلیه کارت های عضو شتاب
- ✓ دانلود فوری مقاله پس از پرداخت آنلاین
- ✓ پشتیبانی کامل خرید با بهره مندی از سیستم هوشمند رهگیری سفارشات