



# A novel path toward methanol and olefins production fueled by syngas via a coupling of coke-oven gas reforming with pulverized coke chemical looping combustion



Dong Xiang<sup>a</sup>, Shuai Liu<sup>a</sup>, Junjie Xiang<sup>b</sup>, Yan Cao<sup>a,b,\*</sup>

<sup>a</sup> College of Chemistry & Chemical Engineering, Anhui University, Hefei 230601, PR China

<sup>b</sup> Institute for Combustion Science and Environmental Technology (ICSET), Department of Chemistry, Western Kentucky University (WKU), Bowling Green, KY 42101, USA

## ARTICLE INFO

### Keywords:

Coke-oven gas-to-olefins  
Pulverized coke  
Chemical looping combustion  
Dry-steam reforming  
Process coupling and integration

## ABSTRACT

Efficient utilization of a large quantity of coke-oven gas (COG) to produce methanol and further olefins is an important technical path toward coal-to-chemicals. The current COG-to-olefins process (CGTO) suffers from inefficient utilization of hydrogen resource in the COG, limited olefins productivity, lower energy efficiency, and ultimately uncompetitive in product cost. Its major technical issues are the insufficient carbon supply and energy intensification. This study provided a novel technical path toward olefins production fueled by syngas from efficient coupling of COG reforming with pulverized coke chemical looping combustion (PC<sub>CLC</sub>). The CO<sub>2</sub> generated by the PC<sub>CLC</sub> was used as carbon source to effectively adjust hydrogen-to-carbon ratio of syngas to 2.0, ideally adapting to methanol production first and further olefins. The coupling and integration in material streams and energy utilization were considered in the new process. Modelling and integration results supported the competitiveness of this novel process, revealing that its hydrogen efficiency and exergy efficiency can be increased to 43% and 60%, comparing to only 29% and 52% in the CGTO. The olefins capacity was also increased from 0.6 Mt/y in the CGTO to 0.9 Mt/y by an additional consumption of economic pulverized coke 0.43 Mt/y. Although total capital investment of the new process was 21% higher than the CGTO, the unit capital investment and product cost were 19% and 6% lower because of its larger olefins capacity.

## 1. Introduction

Coke is a major raw material for metallurgy industries via coal carbonization processes in coking plants, in which a by-product coke-oven gas (COG) is generated. It is a hydrogen-methane-enriched fuel gas, containing H<sub>2</sub> in 58–60 vol% and CH<sub>4</sub> in 23–27 vol%. The other constituents include CO (5–8 vol%), CO<sub>2</sub> (less than 3 vol%), and small quantities of other hydrocarbons and air pollutants [1,2]. The COG production had reached as high as  $2.0 \times 10^{11}$  m<sup>3</sup> only in 2015 in China [3]. However, most of the COG is currently burnt, leading to a considerable waste of energy and resource, and relevant environmental problems. Considering the valuable hydrogen resource, the implementation of highly efficient and clean utilization of the COG can play a pivotal role in reducing dependency on oil and natural gas.

The alternation of the direct heat and power utilization of the COG is its derived high-value chemicals. Among major coal-derived chemical production lines, COG-to-olefins (CGTO) is feasible and promising with significant increment of product value. The present feedstock of

methanol production in China is coal-63.7%, natural gas-23.0%, and COG-11.3% [4]. The methanol-to-olefins has been industrialized, therefore the COG-derived olefins production can also be industrialized similarly. The CGTO can contribute to the self-sufficiency of olefins and reduce dependency on oil and coal. This is especially beneficial for China. However, the current CGTO is far more effective in terms of hydrogen resource utilization and energy efficiency, leading to an uncompetitive in its economics.

Regarding the utilization efficiency of hydrogen resources in the COG, the ideal molar ratio of (H<sub>2</sub> - CO<sub>2</sub>)/(CO + CO<sub>2</sub>) (defined as the R value) in syngas for methanol and olefins synthesis is about 2. In contrast, the conventional steam reforming of the COG suffers from a higher R value of about 4–5, and alternatively a lower R value less than 2 through the CO<sub>2</sub> dry reforming. The currently applied partial oxidation of the COG toward syngas with the R value of about 3. The partial oxidation approach still faces the demand for the readjustment of the R value, generally in an inefficient measure via the hydrogen oxidation of the COG. This approach also inevitably requires a higher power-

\* Corresponding author.

E-mail address: [yan.cao@wku.edu](mailto:yan.cao@wku.edu) (Y. Cao).

## Nomenclature

### Abbreviations

C	carbon
R	molar ratio of $(H_2 - CO_2)/(CO + CO_2)$
S	steam
OC	oxygen carrier
EI	equipment investment
PC	pulverized coke
ASU	air separation unit
COG	coke-oven gas
FCI	fixed capital investment
MSU	methanol synthesis unit
TPC	total product cost
AGRU	acid gas removal unit
CGTO	coke-oven gas-to-olefins
CLCU	chemical looping combustion unit
DSRU	dry-steam reforming unit
MPOU	methane partial oxidation unit
MTOU	methanol-to-olefins unit
CGTOCR	COG-to-olefins with CO <sub>2</sub> recycle
PC <sub>CLC</sub> -CGTO	PC CLC-assisted COG-to-olefins

### Notations in formulation

$\varphi$	hydrogen utilization
$\eta$	exergy efficiency
$\theta$	domestic-made factor
$C_{AC}$	administrative cost
$C_D$	depreciation cost
$C_{DSC}$	distribution and selling cost
$C_{GET}$	gross-earnings tax
$C_{O\&M}$	operating & maintenance cost
$C_{POC}$	plant overhead cost
$C_R$	raw material cost
$C_U$	utilities cost
$EI_j^r$	reference equipment investment of unit $j$
$E_{x,out}$	outlet exergy
$E_{x,in}$	inlet exergy
$E_{x,ch}$	chemical exergy
$E_{x,ph}$	physical exergy
$RF_i$	ratio factor of component $i$
$S_j$	practical scale of unit $j$
$S_j^r$	reference scale of unit $j$
$sf$	scale factor

consumed air separation process. Overall, the efficient and cost-effective utilization of valuable hydrogen in the COG for high-value chemical production will be a crucial technical challenge in the current coal coking industry. In terms of the material balance, the simple carbon input in syngas seems a proper approach to adjust its R value in the COG-to-syngas process, and thus the consequent optimizations of the involved energy efficiency would be essential for technical feasibility, cost reduction, and minimization of environmental stress.

There are a few conceptive designs of co-feeding of coal and COG to realize the carbon input for the adjustment of the R value of syngas. Lin et al. [5] proposed the adjustment of the R value via reforming of coal gasified gas with rich-CH<sub>4</sub> separated from the COG for methanol production, achieving fuel saving and CO<sub>2</sub> reduction by about 5% and 70%. Hao et al. [6] further proposed a polygeneration system of methanol and dimethyl ether production, in which coal gasified gas is reformed with the COG in an oxygen-permeable membrane reactor. The purposes of these researches are to improve coal utilization efficiency and reduce CO<sub>2</sub> emissions of coal based chemicals production processes. On the other hand, Bermudez et al. [7] proposed a CO<sub>2</sub> dry reforming process of the COG for methanol production. Yi et al. [2] proposed the CO<sub>2</sub>-recycled dry reforming of the COG in the methanol production, achieving energy conservation by 5–10% and CO<sub>2</sub> reduction by 70%. However, the costly pure CO<sub>2</sub> supply separated from tail gas will inevitably result in a significant energy penalty. Fortunately,

chemical looping combustion (CLC) can provide the pure CO<sub>2</sub>, excluding costly separation of oxygen in air or CO<sub>2</sub> in flue gas [8,9]. CLC uses solid oxygen carrier (OC), rather than oxygen in air, to oxidize fuels in a fuel reactor (FR), and solid OC later is oxidized by air in another air reactor (AR) by means of recirculation of OC between the FR and AR [10,11]. The gases from the fuel reactor are primarily CO<sub>2</sub> and H<sub>2</sub>O, in which the H<sub>2</sub>O can be easily separated by condensation and thus a high concentrated CO<sub>2</sub> can be achieved [12]. There are additional benefits of the CLC, such as non-flammable combustion toward the eliminated NO<sub>x</sub> emissions and efficient control of other air pollutants based on decreased gas production.

Among current and emerging technologies for CO<sub>2</sub> capture, CLC is a particularly highly-efficient approach [13]. Up to date, CLC has been demonstrated with natural gas, syngas, liquid fuels, and even solid fuels such as biomass and coal [14]. The initial researches were focused on gas fueled CLC, followed by solid fuels in recent years, especially for coal since it plays an important role in power generation as well as being major source of greenhouse emissions. Tests with a bench-scale reactor of the coal-fuel CLC have shown 90–95% coal char conversion and > 99% volatile conversion [9,15]. Several conceptive designs regarding coal-fueled CLC (anthracite) for power consumption were conducted [16,17], achieving more than 10% of the net electricity efficiency benefit and as low as 96 kg/MWh of CO<sub>2</sub> emissions. The chemical looping uncoupling has been specially developed for efficient

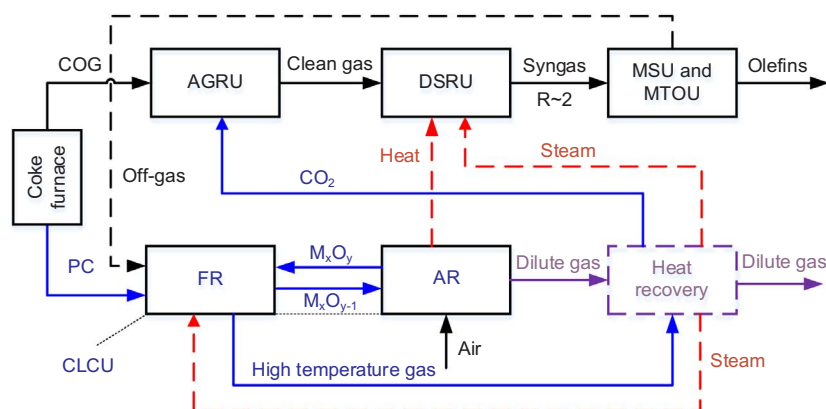

Fig. 1. Concept diagram of the PC<sub>CLC</sub>-CGTO process.

متن کامل مقاله

دریافت فوری ←

**ISI**Articles

مرجع مقالات تخصصی ایران

- ✓ امکان دانلود نسخه تمام متن مقالات انگلیسی
- ✓ امکان دانلود نسخه ترجمه شده مقالات
- ✓ پذیرش سفارش ترجمه تخصصی
- ✓ امکان جستجو در آرشیو جامعی از صدها موضوع و هزاران مقاله
- ✓ امکان دانلود رایگان ۲ صفحه اول هر مقاله
- ✓ امکان پرداخت اینترنتی با کلیه کارت های عضو شتاب
- ✓ دانلود فوری مقاله پس از پرداخت آنلاین
- ✓ پشتیبانی کامل خرید با بهره مندی از سیستم هوشمند رهگیری سفارشات