



Contents lists available at ScienceDirect

## Neurocomputing

journal homepage: [www.elsevier.com/locate/neucom](http://www.elsevier.com/locate/neucom)

# Distributed flow network control with demand response via price adjustment

Kazunori Sakurama

Graduate School of Engineering, Tottori University, 4-101 Koyama-Minami, Tottori 680-8552 Japan

## ARTICLE INFO

### Article history:

Received 19 May 2016

Revised 17 January 2017

Accepted 22 February 2017

Available online xxx

### Keywords:

Flow network

Distributed control

Demand response

Price adjustment

Supply constraint

## ABSTRACT

In this paper, we consider a flow network with demand response, namely, demand-side control by adjusting the price of commodities. First, a flow controller is proposed to reduce the imbalance between inflows and outflows on each vertex. This controller is distributed in the sense that the required information to flow managers is only the imbalances on the adjacent vertexes. We derive a necessary and sufficient condition such that the imbalances on all vertexes converge to zero. Next, a price controller is proposed to maintain the supply-demand balance. We reveal that there is a trade-off in the price controller between the stability of the demand system and the effect of the demand restraint. We derive a necessary and sufficient condition of the price controller to satisfy the trade-off. Furthermore, the minimum required supply capacity is derived, which is smaller than the supposed aggregate demand due to the effect of the price adjustment. Finally, the effectiveness of the proposed method is shown by a simulation.

© 2017 Elsevier B.V. All rights reserved.

## 1. Introduction

Control technology for large-scale network systems is getting more and more important to develop sustainable social infrastructures. Especially, flow network control has a wide range of applications, e.g. power systems, traffic systems, water supply systems, heat distribution systems to name a few [1–5]. The flow network control problem has a long history from the earlier references [6,7], and has been studied extensively since then [8–11]. The flow network control problem is an optimization problem to determine flows so as to transport commodities from suppliers to consumers. The flow network consists of edges, vertexes, suppliers, consumers, and the imbalance is defined on each vertex as inflows (and supply) minus outflows (and demand). Then, the flow on each edge is determined so as to make the imbalance zero within the capacity.

In the conventional research, several optimization methods have been developed to solve the flow network control problem [6–11]. These methods are based on centralized manners which require all information on the systems. In contrast, recent research focuses on distributed flow control, with which edges and vertexes maintain themselves by using only local information. In [12,13], a distributed method to determine the proportions of the imbalance into outflows has been proposed in consideration of flow capacities. It is guaranteed that the limit flows are achieved, where flows

on some edges reach their capacities. However, the imbalance might remain in some cases such that the total supply-demand balance is not achieved.

In this paper, we solve this issue by considering a flow network with demand response, namely, demand-side control by adjusting the commodity price. Here, we assume that customers change their demand by the price according to heterogeneous behavior models. First, we propose a flow controller which reduces the imbalance on each vertex. The proposed controller is implemented on each edge in a distributed way, meaning that the required information is only the imbalances on the adjacent vertexes. As a result, it is shown that the imbalance on each vertex converges to zero if and only if the supply and demand are balanced. Next, we propose a price controller to maintain the supply-demand balance. Notice that there is a trade-off in the price adjustment: if the price adjustment is strong, the demand system can be unstabilized; if it is weak, the effect of the demand restraint is not enough to maintain the supply-demand balance. We derive a necessary and sufficient condition for the price controller to satisfy the trade-off. Furthermore, the minimum required supply capacity is derived, which is smaller than the supposed aggregate demand due to the effect of the price adjustment. Finally, a simulation result illustrates the effectiveness of the proposed method.

These results are especially useful for the power control of microgrids. In the microgrids, the main power supply is based on renewable energies, e.g., solar, wind, and biomass [14]. Because the supply of these energies is unstable, the backup power has to

E-mail address: [sakurama@mech.tottori-u.ac.jp](mailto:sakurama@mech.tottori-u.ac.jp)

<http://dx.doi.org/10.1016/j.neucom.2017.02.092>

0925-2312/© 2017 Elsevier B.V. All rights reserved.

Please cite this article as: K. Sakurama, Distributed flow network control with demand response via price adjustment, Neurocomputing (2017), <http://dx.doi.org/10.1016/j.neucom.2017.02.092>

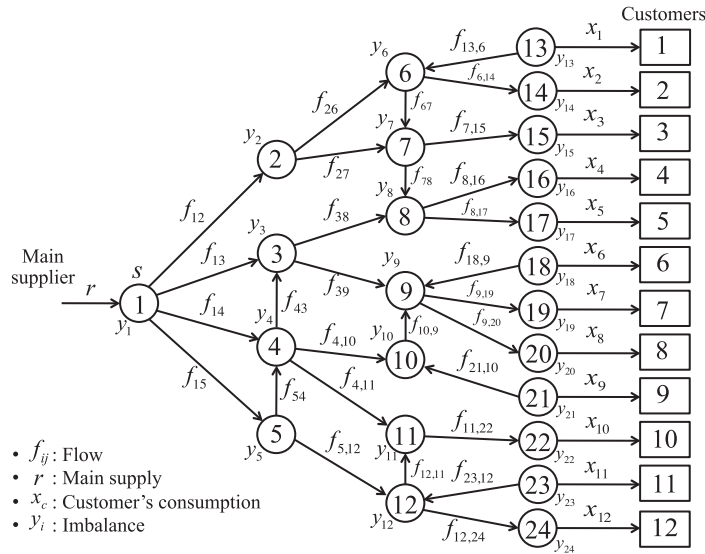

Fig. 1. Example of a network-flow.

be prepared. Introducing demand response to microgrids has been discussed [15,16] since it can reduce the capacity of the backup power. By using the result in this paper, we can reduce the required capacity from the supposed aggregate demand, which could help us to develop sustainable power systems in the future.

Compared to the recent research on the flow network as [12,13], the contributions of this study are as follows: (i) The demand response is introduced to remove the imbalance on vertexes. (ii) An appropriate price adjustment and the minimum required supply capacity are derived. (iii) By employing the proposed flow controller, we show that the flow dynamics is equivalent to the multi-agent system with noise-injected consensus controllers [17,18], and the stability can be analyzed through the graph Laplacian matrix of the network. While the distributed flow network control inspired by the Internet protocols has been researched for decades [19–22], these studies do not consider the imbalance on vertexes.

The rest of the paper is organized as follows: In Section 2, the problem formulation of the flow network and the agent models is given. In Section 3, the main result of this paper is derived, where flow and price controllers are proposed. In Section 4, the effectiveness of the proposed method is verified by a numerical example. Section 5 concludes this paper.

*Notations:* Let  $\mathbb{R}$  be the set of real numbers. The identity matrix is denoted as  $I_n \in \mathbb{R}^n$ . Let  $\mathbf{1}_n \in \mathbb{R}^n$  and  $\mathbf{e}_i \in \mathbb{R}^n$  be the vector all whose components are one and the unit vector whose  $i$ th component is 1, respectively. The Kronecker delta is denoted as  $\delta_{ij}$ , namely,  $\delta_{ii} = 1$  and  $\delta_{ij} = 0$  for  $i \neq j$ . Let  $\sigma(\cdot)$  be the set of the eigenvalues of a matrix.  $\text{Re}(\cdot)$  denotes the real part of a complex number.

## 2. Problem formulation

### 2.1. Agents in the flow network

Consider the flow network  $N = (G, s, C, \varphi)$ , where  $G = (\mathcal{V}, \mathcal{E})$  is a digraph with the vertex set  $\mathcal{V} = \{1, 2, \dots, n\}$  and the edge set  $\mathcal{E} \subset \mathcal{V} \times \mathcal{V}$ ,  $s$  is the vertex connected with the main supplier,  $C = \{1, 2, \dots, m\}$  is the set of customers, and the function  $\varphi : C \rightarrow \mathcal{V}$  indicates the vertexes connected with the customers  $c \in C$ . Note that  $\varphi(c)$  is not necessarily a one-to-one mapping, thus each vertex can have more than one consumer. Assume that  $G$  is simple, weakly-connected and satisfies the condition that if  $(i, j) \in \mathcal{E}$ , then  $(j, i) \notin \mathcal{E}$ . The set  $\bar{\mathcal{E}} \subset \mathcal{V} \times \mathcal{V}$  consists of the pairs of vertexes which

have the opposite edges to  $\mathcal{E}$ , i.e.,

$$\bar{\mathcal{E}} = \{(i, j) \in \mathcal{V} \times \mathcal{V} : (j, i) \in \mathcal{E}\}.$$

Let  $\hat{G} = (\mathcal{V}, \mathcal{E} \cup \bar{\mathcal{E}})$  be the undirected graph derived from  $G$ , including the opposite edges. If  $(i, j) \in \mathcal{E}$ , we say that vertex  $i$  is *in-adjacent* to  $j$ , and that vertex  $j$  is *out-adjacent* from  $i$ . Let  $\mathcal{N}_i^{\text{in}} \subset \mathcal{V}$  and  $\mathcal{N}_i^{\text{out}} \subset \mathcal{V}$  be the sets of the in-adjacent and out-adjacent vertexes to/from  $i \in \mathcal{V}$ , respectively, i.e.,

$$\mathcal{N}_i^{\text{in}} = \{j : (j, i) \in \mathcal{E}\}, \quad \mathcal{N}_i^{\text{out}} = \{j : (i, j) \in \mathcal{E}\}. \quad (1)$$

There are three types of agents in flow network  $N$ : customers, the main supplier and flow managers, whose roles are explained as follow: First, consumer  $c \in C$  consumes commodities at vertex  $\varphi(c) \in \mathcal{V}$ . Let  $x_c(t) \in \mathbb{R}$  be the amount consumed by  $c$  at time  $t \geq 0$ . Note that we can assume that customer  $c$  supplies commodities as a private retailer. Whether  $c$  consumes or supplies can be recognized by the sign of  $x_c(t)$ . If  $x_c(t) > 0$ , consumer  $c$  consumes, and if  $x_c(t) < 0$ , it supplies. Next, the main supplier supplies commodities from the vertex  $s \in \mathcal{V}$ . Let  $r(t)$  be the supplied amount. Moreover, the main supplier determines the price  $p(t)$  of the commodities and show them to the customers. Finally, flow manager  $(i, j)$  manages the flow  $f_{ij}(t) \in \mathbb{R}$  at edge  $(i, j) \in \mathcal{E}$ . If  $f_{ij}(t) > 0$ , the direction of the flow is from vertex  $i$  to  $j$ . If  $f_{ij}(t) < 0$ , the direction is opposite.

**Example 1.** An example of the flow network is shown in Fig. 1. The graph  $G = (\mathcal{V}, \mathcal{E})$  is given by the vertex set  $\mathcal{V} = \{1, 2, \dots, 24\}$  and the edge set  $\mathcal{E} \subset \mathcal{V} \times \mathcal{V}$

$$\begin{aligned} \mathcal{E} = \{ & (1, 2), (1, 3), (1, 4), (1, 5), (2, 6), (2, 7), (3, 8), \\ & (3, 9), (4, 3), (4, 10), (4, 11), (5, 4), (5, 12), (6, 7), \\ & (6, 14), (7, 8), (7, 15), (8, 16), (8, 17), (9, 19), \\ & (9, 20), (10, 9), (11, 22), (12, 11), (12, 24), (13, 6), \\ & (18, 9), (21, 10), (23, 12)\}. \end{aligned}$$

The main supplier supplies the commodities from vertex  $s = 1$ . The set of customers is given by  $C = \{1, 2, \dots, 12\}$ , and the function  $\varphi : C \rightarrow \mathcal{V}$  is given as follows:

$$\begin{aligned} \varphi(1) &= 13, \quad \varphi(2) = 14, \quad \varphi(3) = 15, \quad \varphi(4) = 16, \\ \varphi(5) &= 17, \quad \varphi(6) = 18, \quad \varphi(7) = 19, \quad \varphi(8) = 20, \\ \varphi(9) &= 21, \quad \varphi(10) = 22, \quad \varphi(11) = 23, \quad \varphi(12) = 24. \end{aligned}$$

As shown in Fig. 1,  $r(t)$  flows in at vertex  $s = 1$ ,  $x_c(t)$  flows out of vertex  $\varphi(c)$  and  $f_{ij}(t)$  flows through edge  $(i, j)$ .

متن کامل مقاله

دریافت فوری ←

**ISI**Articles

مرجع مقالات تخصصی ایران

- ✓ امکان دانلود نسخه تمام متن مقالات انگلیسی
- ✓ امکان دانلود نسخه ترجمه شده مقالات
- ✓ پذیرش سفارش ترجمه تخصصی
- ✓ امکان جستجو در آرشیو جامعی از صدها موضوع و هزاران مقاله
- ✓ امکان دانلود رایگان ۲ صفحه اول هر مقاله
- ✓ امکان پرداخت اینترنتی با کلیه کارت های عضو شتاب
- ✓ دانلود فوری مقاله پس از پرداخت آنلاین
- ✓ پشتیبانی کامل خرید با بهره مندی از سیستم هوشمند رهگیری سفارشات