

Experimental implementation of an optimum viscoelastic vibration absorber for cubic nonlinear systems

Klaas B. Bronkhorst^a, Mariano Febbo^{b,*}, Eduardo M.O. Lopes^a, Carlos A. Bavastrì^a

^a Department of Mechanical Engineering, Federal University of Paraná – UFPR, CEP 81531-990 Curitiba, PR, Brazil

^b Instituto de Física del Sur (IFISUR), Departamento de Física, Universidad Nacional del Sur (UNS), CONICET, Av. L. N. Alem 1253, B8000CPB-Bahía Blanca, Argentina

ARTICLE INFO

Keywords:

Viscoelastic dynamic vibration absorber
Cubic nonlinear systems
Vibration control

ABSTRACT

The design of vibration control devices requires an accurate knowledge of the dynamic behavior of the system to be controlled. The present work aims to propose a methodology to identify a single degree-of-freedom nonlinear system with cubic stiffness and a methodology for the optimum design of a viscoelastic dynamic absorber with linear behavior, intending to reduce the vibrations of the cubic system to as low a level as possible. The identification is performed through an inverse process. The nonlinear model with cubic stiffness used in this work produces a transmissibility curve which is fitted using the least squares method to the experimentally obtained transmissibility curve. With the identified physical parameters of the nonlinear system, a viscoelastic dynamic vibration absorber is optimally designed. To achieve these goals, the following tools are employed: the concept of generalized equivalent parameters, to couple the viscoelastic dynamic absorber to the nonlinear system; the four-parameter fractional derivative model, to represent the viscoelastic material; and nonlinear optimization techniques and the harmonic balance method to solve the nonlinear equation of motion. Numerical simulations and the corresponding physical implementation of the system are carried out and their results are compared.

1. Introduction

Nonlinear dynamical systems have been intensively studied in recent decades by several researchers. Among them it is possible to mention the works by Nayfeh and Mook [1], Worden and Tomlinson [2], and Thomsen [3]. Several nonlinear systems have been studied by different analytical and numerical means and by employing different methods of solution as, for example, the harmonic balance method, the multiple scales method, the averaging method, and the Volterra series. More recently, Johannessen [4] describes an analytical method of solution for a Duffing oscillator with damping, assuming a solution using the Jacobi elliptic functions. In a two degree-of-freedom system (2DOF), Gatti et al. [5], Gatti et al. [6] use the harmonic balance method and the averaging method to verify the interaction at the resonances of a nonlinear system with a linear structure to which the former is coupled.

The study of nonlinearities also includes the development of models of isolators, as shown in the work by Ravindra and Mallik [7], in which the insulator is patterned with nonlinear stiffness and damping. In order to increase passenger's comfort, Silveira et al. [8] show the positive results of using bilinear dampers in vehicles. Other examples are the contributions by Peng et al. [9], who apply the harmonic balance

method (MHB) to check the influence of cubic nonlinearities on the transmissibility; and Xiao et al. [10], who study a model with cubic nonlinear damping, which is a function of both velocity and displacement. Other nonlinearity sources in physical systems are: piezoelectric materials with nonlinear relationship between stress-strain and electric field displacement [11,12], rotating systems in which nonlinearity stems from the reaction force of a bearing [13], and systems in which the interaction between cable and beam generates nonlinearity [14].

It is stressed that nonlinearities can simply appear due to the so called Sommerfeld effect, as studied in Balthazar et al. [15]. In this study, fractional stiffness and damping nonlinearities are modeled for non-ideal systems, such as portal frames. In addition, studies comprising multiple degree-of-freedom systems are: Barry et al. [16], presenting the study of a beam in which nonlinearity stems from the axial stress and the same nonlinear spring; Gayesh et al. [17], studying a beam with nonlinear springs and concentrated mass; Huang et al. [18], focusing their study on a curved beam subjected to a uniform harmonic excitation at the base; and Rudenko and Solodov [19], describing the spread of vibration waves in nonlinear multiple degree-of-freedom systems (n-DOF).

Vibration control is a very important matter since the presence of undesirable vibrations in machines is very common. Ahmadabadi and

* Corresponding author.

E-mail address: mfebbo@uns.edu.ar (M. Febbo).

Khadem [20] use a nonlinear dynamic vibration absorber (NDVA) for controlling the vibration of a beam. Gourdon et al. [21] control vibrations during earthquakes also using an NDVA. It is also possible to control a system with a modification of the nonlinear characteristics by using pole placement, as shown by [22,23]. The control of nonlinear systems is studied by Ji and Zhang [24] by applying a dynamic vibration neutralizer to a nonlinear system. Sun et al. [25] present an experimental study of a vibration attenuation system with a primary nonlinearity using a cubic NDVA working in parallel with a pendulum. Bavastri et al. [26] and Febbo et al. [27] present a methodology for an optimal design of viscoelastic dynamic vibration absorbers (VDVAs) with linear behavior applied to cubic nonlinear systems and discuss the influence of temperature on the detuning of these control systems, respectively.

Dynamic vibration absorbers (DVAs) are extensively used in passive vibration control for the sake of simplicity in construction and application. DVAs are secondary mechanical devices coupled to another mechanical system, called primary system, in order to reduce or control vibration and noise in the primary system. They have been in use for a long time in several applications such as the tipping control of vessels [28], vibration control in unbalanced rotating systems [29], and reduction of vibration in cables excited by the wind [30]. Since the first known applications, many papers reporting their efficiency have been presented.

A general theory for the optimization of DVAs in various geometries of generic structures and any damping distribution is presented in Espindola and Silva [31]. The theory is based on the concept of generalized equivalent mass and damping parameters for DVAs. Based on such parameters, it is possible to describe the dynamics of a compound system (DVA plus primary system) using only the generalized coordinates (degrees of freedom) of the primary system. This is achieved despite the additional degrees of freedom that the compound system will have due to its coupling to the DVA. This theory has been successfully applied, as reported Espindola et al. [32], Espindola et al. [33], Espindola et al. [34], and Bavastri et al. [26].

Technological and scientific advances regarding viscoelastic materials make the construction of DVAs even simpler. The behavior of viscoelastic materials is represented by mathematical models such as the four-parameter fractional derivative model in which a few parameters can accurately represent the dynamic behavior [35–37]. Saidi et al. [38] use a viscoelastic DVA (VDVA) formed by a mass and a sandwich beam to reduce low frequency vibration in floors. Balthazar et al. [39] studied a non-ideal Duffing system with fractional damping applied to an oscillator, as an alternative damping model for the viscoelastic behavior. They found regular and non-regular motions of the system, which are possibly useful from a passive control viewpoint. Bavastri et al. [26], Doubrava Filho et al. [40], and Espindola et al. [33] successfully apply viscoelastic materials in the construction of VDVAs wherein the viscoelastic material is responsible both for stiffness and damping.

For vibration control it is important to know the primary system. One of the most established methods generally applied to linear systems is known as ‘inverse problem of identification’. In this process, system curves are obtained experimentally in order to find out the physical parameters that characterize the associated systems. Procedures such as nonlinear optimization techniques are generally intended to identify such parameters. Although less generic, parametric methods may also be used. For example, Malaktar and Nayfeh [41] perform a parametric identification of a beam with cubic geometry and compare it with the result of the identification made by nonlinear optimization.

In the present work, we present a global methodology to the optimal design of a viscoelastic dynamic absorber to reduce the vibration levels, in a broad band of frequency, for a cubic nonlinear primary system, considering the identification of the primary system and the optimal design of the absorber. In this sense, the authors consider the following points as original contributions:

- The utilization of the Generalized Equivalent Parameters (GEPs) to model a compound system -cubic nonlinear primary system plus a viscoelastic dynamic vibration absorber (VDVA). That allows the description of the dynamics of the compound system only as a function of the coordinates of the nonlinear primary system, thus simplifying the mathematical formulation of the problem using the transmissibility function.
- The implementation of a methodology to identify a cubic nonlinear primary system based on sweep-up and sweep-down transmissibility curves at constant acceleration, using nonlinear optimization techniques.
- The implementation of a methodology to optimize the VDVA attached to the cubic nonlinear primary system applying the GEPs model.
- The realization of the physical systems and the validation of the theoretical findings with experimental results.

The paper is structured as follows. First, the mathematical formulation of the primary system based on the complex transmissibility function of the primary system, regarding the base excitation phase, is introduced. Then, a review of the mathematical model of the compound system, based on a previous work by Bavastri et al. [26] using GEPs model, is presented. A global methodology to apply a VDVA in a cubic nonlinear primary system, considering the identification of the primary system and the optimal design of the absorber, is detailed in the following section. Experimental results are then presented, including the identification of the SDOF cubic nonlinear system and the application of the optimally designed VDVA to mitigate the vibrations of the primary system. These results are compared to their numerical counterparts and discussed. Finally, some concluding remarks are provided.

2. Mathematical formulation

In Bavastri et al. [26], the mathematical model used to obtain the dynamic response of an optimum viscoelastic absorber attached to a cubic nonlinear system is obtained using the method of generalized equivalent parameters. Here, to enable the use of experimental data, a corresponding expression based on the estimation of transmissibility is obtained in order to, first, identify the parameters of the cubic nonlinear system and, second, model the compound system (primary system and absorber).

2.1. Primary system

An SDOF cubic nonlinear system is schematically presented in Fig. 1.

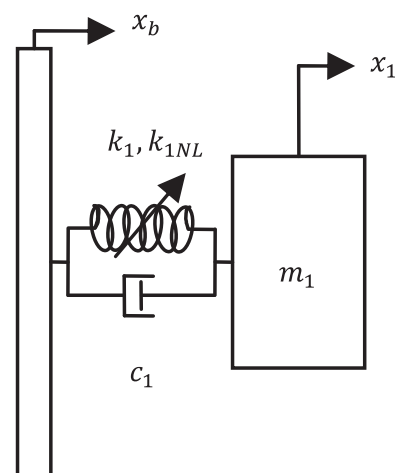

Fig. 1. Cubic nonlinear system excited by its base.

متن کامل مقاله

دریافت فوری ←

ISIArticles

مرجع مقالات تخصصی ایران

- ✓ امکان دانلود نسخه تمام متن مقالات انگلیسی
- ✓ امکان دانلود نسخه ترجمه شده مقالات
- ✓ پذیرش سفارش ترجمه تخصصی
- ✓ امکان جستجو در آرشیو جامعی از صدها موضوع و هزاران مقاله
- ✓ امکان دانلود رایگان ۲ صفحه اول هر مقاله
- ✓ امکان پرداخت اینترنتی با کلیه کارت های عضو شتاب
- ✓ دانلود فوری مقاله پس از پرداخت آنلاین
- ✓ پشتیبانی کامل خرید با بهره مندی از سیستم هوشمند رهگیری سفارشات