



The effects of ultrasonic agitation on supercritical CO₂ copper electroplating



Ho-Chiao Chuang*, Hsi-Min Yang, Guan-Lin Wu, Jorge Sánchez, Jenq-Huey Shyu

Department of Mechanical Engineering, National Taipei University of Technology, Taipei 10608, Taiwan

ARTICLE INFO

Keywords:

Ultrasonic irradiation
Supercritical CO₂ electroplating
Grain refinement

ABSTRACT

Applying ultrasound to the electroplating process can improve mechanical properties and surface roughness of the coating. Supercritical electroplating process can refine grain to improve the surface roughness and hardness. However, so far there is no research combining the above two processes to explore its effect on the coating. This study aims to use ultrasound (42 kHz) in supercritical CO₂ (SC-CO₂) electroplating process to investigate the effect of ultrasonic powers and supercritical pressures on the properties of copper films. From the results it was clear that higher ultrasonic irradiation resulted in higher current efficiency, grain refinement, higher hardness, better surface roughness and higher internal stress. SEM was also presented to verify the correctness of the measured data. The optimal parameters were set to obtain the deposit at pressure of 2000 psi and ultrasonic irradiation of 0.157 W/cm³. Compared with SC-CO₂ electroplating process, the current efficiency can be increased from 77.57% to 93.4%, the grain size decreases from 24.34 nm to 22.45 nm, the hardness increases from 92.87 Hv to 174.18 Hv, and the surface roughness decreases from 0.83 μm to 0.28 μm. Therefore, this study has successfully integrated advantages of ultrasound and SC-CO₂ electroplating, and proved that applied ultrasound to SC-CO₂ electroplating process can significantly improve the mechanical properties of the coating.

1. Introduction

1.1. Disadvantages of electroplating

Electroplating is a process that uses electrolysis to form a thin coherent metal coating on the surface of metal or other materials. It is primarily used to change the surface properties of an object (e.g. corrosion protection, abrasion and wear resistance, conductivity, brightness, aesthetic qualities, etc.) Recently, this technique has been widely used in microelectromechanical systems (MEMS) because of the ability to fabricate high aspect ratio and net-shape structures at reduced cost [1]. However, micro-electroplating often has poor mechanical properties which leads to failure of the electronic devices, so it is an issue to improve electroplating quality to increase the reliability of electronic devices.

1.2. Ultrasonic-assisted electroplating

The use of ultrasound in the electrodeposition causes cavitation phenomena such as acoustic streaming, micro-jetting, shock waves, mass-transfer enhancement from/to the electrode and surface cleaning to improve many different electrochemical processes [2]. Diverse cavitation phenomena can enhance the transfer of metal ions in the bath, affect the nucleation process and refine the grain size [3,4,5]. In 2010,

Kim et al. used ultrasonication during electrodeposition of Cu on a silicon wafer and discovered that ultrasonication provided a significant increase in elastic modulus and hardness and decrease in grain size [6]. In 2010, Niu et al. prepared multilayered Ni coatings with higher hardness and better adhesion performance by ultrasound-assisted electrodeposition compared to traditional electroplating [7]. In 2015, Tudela et al. discussed the effect of ultrasonic power on characteristics of Ni thin coating by ultrasound-assisted electrodeposition. The team concluded that Ni coatings electrodeposited using an ultrasonic power of 0.124 W/cm³ presented the highest degree of grain refinement in the surface and the highest microhardness values [5]. In 2016, Zhao et al. investigated the effect of ultrasonic agitation on adhesion strength of micro electroforming Ni layer on Cu substrate and indicated that ultrasonic agitation increases the crystallite size, the real surface area and adhesion strength, and reduces the compressive pressure. Then micro pillar arrays were fabricated under the optimal parameters (200 W, 40 kHz) and the residual rate is increased by about 17% [8,9]. Moreover, the implementation of ultrasound in composite electroplating processes can improve the dispersion and de-agglomeration of particles in the electroplating bath to increase the surface quality, mechanical properties and corrosion resistance of the coating [1,2,4,6]. In 2016, Camargo et al. used different combinations of ultrasonic power and current density to deposit Zn-TiO₂ with ultrasonic bath-setup. The composite Zn-TiO₂ plated at 20 A/dm² under 28 and 53 mW/cm³

* Corresponding author.

E-mail address: hchuang@ntut.edu.tw (H.-C. Chuang).

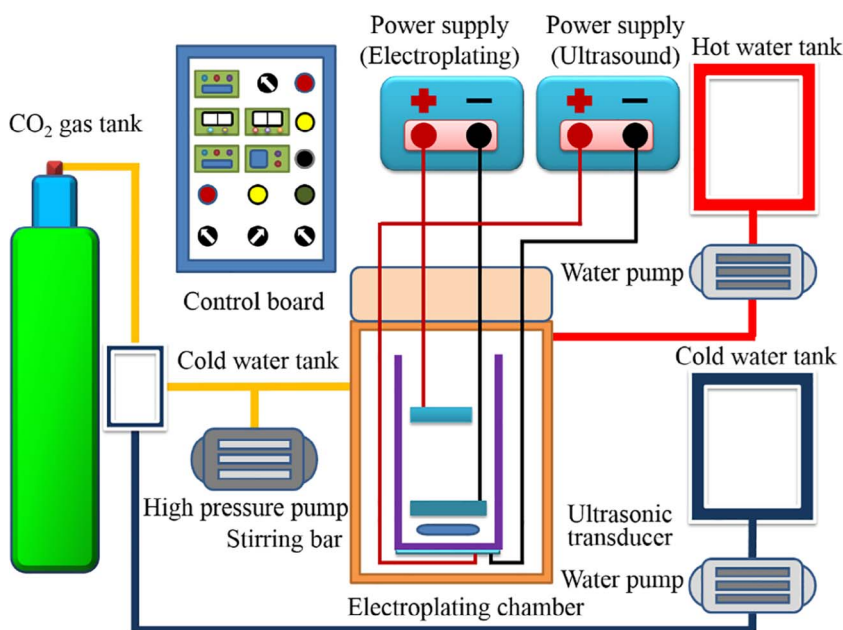

Fig. 1. Schematics of ultrasound-assisted supercritical electroplating equipment.

ultrasonic power densities exhibited dispersion of TiO₂, compactness of coating and enhancement of hardness [10]. In 2016, Ataie et al. discussed the effect of tribological properties of Zn-Ni/nano Al₂O₃ composite coatings produced by ultrasonic assisted pulse plating with different ultrasonic powers. The team concluded that by increasing the ultrasonic power, alumina content and its dispersion in the coating was improved significantly, size of the grains would be reduced leading to decreased roughness of the coating, subsequently hardness and wear resistance of coating will improve [11].

1.3. Supercritical electroplating

The supercritical phase presented in 1822 by Cagnaird de la Tour has many advantages: low surface tension, high diffusivity, permeability and density [12]. Because of the unique characteristics of supercritical fluids, Sone et al. mixed supercritical CO₂ with surfactants to form a stable emulsion solution for electroplating and obtained good quality with better surface coverage, higher hardness and finer grains in the electroplated film [13]. The team also concluded that supercritical electroplating process under constant agitation with temperature of 325 K and pressure of 10 MPa will obtain sufficient emulsion of the fluid and improve the electroplated film's morphology and reduce the formation of voids [14]. In 2013, Sone et al. [15,16,17] explored the effects of supercritical plating pressure on grain size and found the minimum grain size was observed at a high pressure state (15 MPa). Moreover, Cu pillars without voids were achieved successfully by supercritical electroplating process [18,19]. In 2014, Chuang et al. used supercritical electroplating before and after a round of heat treatment to obtain nickel-filled TSVs and analyzed its electrical resistance and vacuum sealing [20]. Furthermore, the effect of supercritical copper electroplating parameters (pressure and current density) was investigated in TSV chips and discovered a supercritical pressure of 2000 psi and a current density of 3 A/dm² without surfactants giving off the best quality of electroplating filling and hermeticity [21]. In 2016, Li et al. filled void-free Ni-P alloy into aspect ratio (1:8) micro-holes and presented that the deposition efficiency and morphology were significantly affected by the deposition time and current density [22]. In 2016, high aspect ratio (1:490) copper nanowires were fabricated by supercritical electroplating, post-supercritical electroplating and traditional electroplating process and revealed supercritical electroplating has a significant electroplating velocity with advantages of reducing defects and refining grain [23]. Furthermore, the team

discussed the effect of pressure and material characterization in thin film and TSV fabricated by supercritical electroplating, post-supercritical electroplating and traditional electroplating process. The results showed that the films fabricated by the supercritical electroplating and post-supercritical electroplating had enhanced mechanical properties and TSV chips filled by the supercritical electroplating and post-supercritical electroplating had shorter fabrication time when compared to the traditional electroplating [24].

1.4. Ultrasound + supercritical electroplating

Numerous studies have applied ultrasound to the electroplating process to obtain the coating with grain refinement, surface leveling, hardness increasing, and adhesion enhancement. Supercritical electroplating process with high diffusion, permeability and sealing advantages not only has the fastest deposition rate, but also can refine grains to improve the surface roughness and hardness. Application of ultrasound to the sc-CO₂ can enhance the emulsification effect and even replace surfactants as reported by Timko et al. [25]. Gao et al. [26–28] recently reported fabrication processes with ultrasound under high pressure CO₂ and obtained more efficient production of materials with enhanced properties. Although both of the electroplating processes can improve the mechanical properties of the coating, so far, no study has combined these two processes to investigate the effect on the coating characteristics.

In this study, ultrasonic irradiation (42 kHz) was applied to supercritical electroplating process to investigate the influence of ultrasonic powers and supercritical chamber pressures on the properties of copper films. The deposit with finer grain, smaller morphology and higher hardness was expected to obtain by this method. Additionally, ultrasound-assisted supercritical CO₂ (SC-CO₂) electroplating have been compared to SC-CO₂ electroplating, ultrasound-assisted electroplating and traditional electroplating to verify the effect of ultrasonic application on SC-CO₂ electroplating.

2. Experimental procedures

2.1. Equipment and materials

For this study, ultrasound agitation was applied to supercritical electroplating process to perform electroplating; equipment schematics are as shown in Fig. 1. High purity (99.99%) CO₂ was used for the

متن کامل مقاله

دریافت فوری ←

ISIArticles

مرجع مقالات تخصصی ایران

- ✓ امکان دانلود نسخه تمام متن مقالات انگلیسی
- ✓ امکان دانلود نسخه ترجمه شده مقالات
- ✓ پذیرش سفارش ترجمه تخصصی
- ✓ امکان جستجو در آرشیو جامعی از صدها موضوع و هزاران مقاله
- ✓ امکان دانلود رایگان ۲ صفحه اول هر مقاله
- ✓ امکان پرداخت اینترنتی با کلیه کارت های عضو شتاب
- ✓ دانلود فوری مقاله پس از پرداخت آنلاین
- ✓ پشتیبانی کامل خرید با بهره مندی از سیستم هوشمند رهگیری سفارشات