



# Electrothermal dynamics-conscious lithium-ion battery cell-level charging management via state-monitored predictive control



Changfu Zou <sup>a, \*\*</sup>, Xiaosong Hu <sup>b, \*</sup>, Zhongbao Wei <sup>c</sup>, Xiaolin Tang <sup>b</sup>

<sup>a</sup> Department of Electrical Engineering, Chalmers University of Technology, Gothenburg 41296, Sweden

<sup>b</sup> State Key Laboratory of Mechanical Transmissions, Department of Automotive Engineering, Chongqing University, Chongqing 400044, China

<sup>c</sup> School of Electrical & Electronic Engineering, Nanyang Technological University, Singapore 639798, Singapore

## ARTICLE INFO

### Article history:

Received 10 February 2017

Received in revised form

1 September 2017

Accepted 11 September 2017

Available online 17 September 2017

### Keywords:

Lithium-ion battery

Battery charging control

Model predictive control

Electrothermal model

State-of-charge estimation

## ABSTRACT

Lithium-ion battery charging management has become an enabling technology towards a paradigm shift of electrified mobility. Fast charging is desired for convenience improvements but may excessively degrade battery's health or even cause safety issues. This paper proposes a novel algorithm to manage battery charging operations using a model-based control approach. Based on a fully coupled electro-thermal model, the fast charging strategy is formulated as a linear-time-varying model predictive control problem, for the first time. Constraints are explicitly imposed to protect the battery from overcharging and overheating. To enable the state-feedback control, unmeasurable battery internal states including state-of-charge and core temperature are estimated via a nonlinear observer using noisy measurements of current, voltage, and surface temperature. Illustrative results demonstrate that the proposed approach is able to optimally balance time and temperature increase. In addition, it is shown from simulations that the model predictive control based charging algorithm appears promising for real-time implementation.

© 2017 Elsevier Ltd. All rights reserved.

## 1. Introduction

Due to their advantageous properties including high energy and power density, no memory effect, low maintenance requirement, and relatively friendly environment effect, lithium-ion batteries have been recognised as the most promising cell chemistry for applications like electric vehicles and portable electronic devices [1]. To utilise the battery-powered equipment, safety and economy are two critical concerns. Temperature is a particularly important factor impacting battery's safety and health [2]. For example, a high temperature will accelerate the battery ageing process and may even cause thermal runaway and explosion [3]. In this regard, it is necessary to monitor and manage battery thermal behaviours. To facilitate battery utilisations, the required charging time is another significant aspect. Simply increasing the charging rates may cause large heat generation associated with dramatic cell temperature rise. Therefore, for battery charging management, control algorithms that can optimally handle these correlated objectives are

desirable.

The constant-current constant-voltage (CCCV) charging protocol [4] is now widely used for lithium-ion batteries. In this scheme, the battery is charged at a constant current until the terminal voltage reaches its upper limit, and then, the charging process enters the CV stage. When the current drops below a threshold value, the operation is terminated. It was found by Notten et al. [5] that the depleted batteries can be recharged with high currents for a short time but do not sacrifice significant lifetime. Then, by these authors, a boost-charging approach was proposed to shorten the charging time. Motivated by this, a multiple-stage constant-current charging was proposed in Ref. [6], where the operation starts with the largest current in the first stage followed by sequentially stepwise reduced currents. A CC-CCCV protocol was analysed in Ref. [7] to seek for improved charging patterns. In addition, the Taguchi method was adopted in Ref. [8] for LiPB cells under different ageing levels and has been demonstrated advantages in time and energy efficiency over its CCCV-based benchmark. Note that the above well-defined CCCV alternatives may improve the charging performance to some degree. However, these charging strategies in essence are defined without explicitly considering battery in-situ electrical and thermal dynamics. These model-free approaches are considered as heuristic, and the corresponding

\* Corresponding author.

\*\* Corresponding author.

E-mail addresses: [changfu.zou@chalmers.se](mailto:changfu.zou@chalmers.se) (C. Zou), [xiaosonghu@ieee.org](mailto:xiaosonghu@ieee.org) (X. Hu).

solutions for battery charging are often suboptimal.

To overcome the existing issues, model-based algorithms have been devised. The first body of related literature focused on physics-based modelling of battery dynamics. This class of models describes physical phenomena such as intercalation kinetics, lithium-ion diffusion, and electric potential from first principles. For instance, an electrochemical-thermal-ageing battery model consisting of partial differential equations (PDEs) over multiple spatial dimensions was proposed in Ref. [4]. Through resorting to nonlinear electrochemical modelling, an optimisation problem was formulated to minimise intercalation-induced stresses over charging processes [9]. Charging profiles derived from electrochemical model-based optimisation techniques were recently presented in Ref. [10] to avoid lithium deposition. Based on a similar battery model, Sourav and Anwar formulated an open-loop controller to optimise the charging speed and temperature increase [11]. By using an electrochemical-thermal model, a one-step nonlinear model predictive control (MPC)-based charging strategy was developed to reduce the charging time in Ref. [12]. With the same objective but an isothermal electrochemical battery model, a differential flatness-based MPC charging protocol was employed in Ref. [13]. All the above optimisation and control approaches have been shown some merits for battery charging, but mathematically, they are subject to complicated model structures. The associated calibration efforts and computational requirements can be significant and overly expensive, thereby forming a great challenge to their application in commercial battery management systems.

In light of this, attempts have been made to develop charging algorithms using semi-empirical or equivalent circuit models. Instead of modelling electrochemical processes, the system dynamics in circuit models are approximated by several resistors, capacitors, and an ideal voltage source, e.g. in Ref. [14]. Due to their simplicity in parameterization and implementation, these models have been widely studied for battery applications and may be good candidates to solve the charging problem. For example, an off-line optimisation problem was formulated to minimise time and energy loss in Ref. [15]. The similar optimisation problem was then adopted in Ref. [16] with different objectives, namely the charging completion time and increased temperature. By using a simplified circuit model, Abdollahi et al. [17] derived an analytical solution to a linear optimisation problem of battery charging. Depending on a nonlinear electro-thermal-ageing model, Perez et al. [18] designed an open-loop optimal controller with a pseudo-spectral method to solve the embedded optimisation problem. This type of algorithms optimises the charging profile at once and applies its solution to the battery, but does not consider the inevitable noise and disturbance. To close the control loop, Xavier and Trimboli [19] recently synthesised a linear MPC and the first-order resistor-capacitor (RC) model to generate CCCV charging profiles. With the same electrical model but considering a temperature-dependent ohmic resistance through a lookup table, a constrained generalised predictive control (GPC) was proposed in Ref. [20]. However, coupling relationships between thermal and electrical dynamics as well as model-plant mismatches have not been fully addressed. Furthermore, the existing charging strategies often assumed available battery state and parameter information. In fact, the core temperature and state-of-charge (SoC) are difficult to measure during onboard applications [21]. Meanwhile, parameters of the battery model for predicting system charging dynamics, such as resistance and capacitance, are usually dependent on the internal temperature and SoC [22].

This paper leverages battery modelling and estimation techniques and the MPC control methodology to propose a new charging algorithm which is practical for real world

implementation. A high-fidelity mathematical model is utilised to predict battery coupled electrothermal dynamics. Based on the obtained model, a nonlinear adaptive observer is designed to estimate the unmeasurable state variables in real-time in the presence of noise, modelling error, and initial deviation. Finally, the battery charging management problem is formulated within the framework of linear-time-varying (LTV) MPC. Through this model-based approach, constraints are straightforwardly imposed to protect the battery from overcharging, overheating, and safety issues. Extensive simulations are conducted to demonstrate the performance of the proposed strategy in balancing the charging time and temperature increase under different tuning parameter values.

The remainder of this paper is organised as follows. The battery model and estimation algorithm are successively presented in Sections 2 and 3. The MPC-based charging strategy is formulated in Section 4 and then implemented in Section 5. Section 6 points out the limitations of the proposed approach and highlights the potential future work, followed by a conclusion in Section 7.

## 2. Battery model

For model-based charging management, a mathematical model to predict battery system dynamics is first described. The electrical behaviours are captured in the manner of an equivalent circuit consisting of an ideal voltage source, an internal resistor, and two resistor-capacitor (RC) pairs, as illustrated in Fig. 1(a). The state variables required to describe the electrical model are state-of-charge  $SoC(t)$ , and voltages of two RC pairs denoted as  $V_1(t)$  and  $V_2(t)$ . With these notations, the electrical governing equations for a lithium-ion battery can be derived using Kirchhoff's current and voltage laws:

$$\frac{dSoC(t)}{dt} = \frac{I(t)}{3600C_n} \quad (1a)$$

$$\frac{dV_1(t)}{dt} = -\frac{V_1(t)}{R_1C_1} + \frac{I(t)}{C_1} \quad (1b)$$

$$\frac{dV_2(t)}{dt} = -\frac{V_2(t)}{R_2C_2} + \frac{I(t)}{C_2} \quad (1c)$$

where the current  $I(t)$  is defined to be non-negative for charging operations, and  $C_n$  represents the nominal capacity. For an extended range of operations, the electrical model is often nonlinear, as the resistances,  $R_0, R_1, R_2$ , and the capacitances,  $C_1$  and

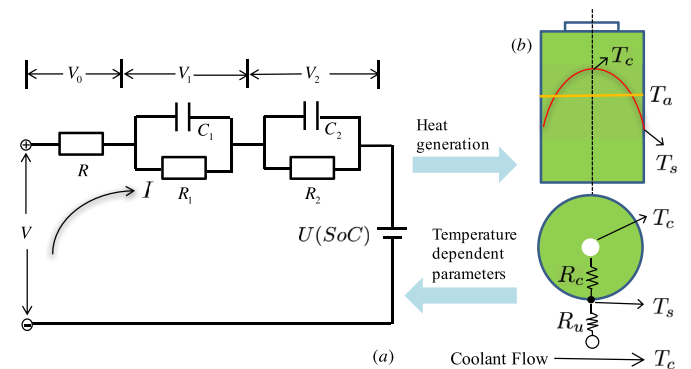

Fig. 1. Illustration of electrothermal modelling for a lithium-ion battery. (a) An equivalent-circuit model of battery electrical dynamics. (b) A thermal model for a cylindrical battery.

متن کامل مقاله

دریافت فوری ←

**ISI**Articles

مرجع مقالات تخصصی ایران

- ✓ امکان دانلود نسخه تمام متن مقالات انگلیسی
- ✓ امکان دانلود نسخه ترجمه شده مقالات
- ✓ پذیرش سفارش ترجمه تخصصی
- ✓ امکان جستجو در آرشیو جامعی از صدها موضوع و هزاران مقاله
- ✓ امکان دانلود رایگان ۲ صفحه اول هر مقاله
- ✓ امکان پرداخت اینترنتی با کلیه کارت های عضو شتاب
- ✓ دانلود فوری مقاله پس از پرداخت آنلاین
- ✓ پشتیبانی کامل خرید با بهره مندی از سیستم هوشمند رهگیری سفارشات