



Coordination of operations in registration channel of data from electrical power system



R. Masnicki*, J. Mindykowski

Faculty of Electrical Engineering, Gdynia Maritime University, Gdynia, Poland

ARTICLE INFO

Article history:

Received 16 May 2016

Received in revised form 9 November 2016

Accepted 3 December 2016

Available online 9 December 2016

Keywords:

Data registration

Synchronization

Data format

Data flow correctness

Electrical power system

ABSTRACT

In the paper, the problem of coordination of operations performed in registration track of the parameters characterizing an electrical power system is discussed. The coordination operations, namely the synchronizations, are carried out in the track during the data transfer between functional blocks. These operations should comply with requirements concerning the correctness of successive stages of data processing and appropriate formats of the transferred data. So, the analysis of sequential correctness and time coordination of aforementioned operations is a key point of the analyzed issue. For solving this problem, firstly, the fluency conditions of data flow for selected configurations of the track for data registration needs were formulated. Next, basing on the case study i.e. designed and constructed instrument for analysis and estimation of electrical power system parameters, the successive stages of data registration track as well as the formats of data in individual operations performed in this device are shown and discussed. The different ways of data block synchronization in transmission between selected blocks and some effects, based on experimentally verified results, are presented and commented on.

© 2016 Elsevier Ltd. All rights reserved.

1. Introduction

The electrical power system can be regarded as huge system network consisting of, among others, electrical power generators, voltage transformers, protection systems, connecting power cables and power receiving devices. All these elements affect the electrical energy. The electrical signals transferring energy are often considered as composed of pure sinusoidal waveforms, they may be subjected to influence a variety of disturbances. The elaborated standards define the types and sizes of disturbance, and the tolerance of various types of equipment to the possible disturbances. The principal standards in this field are the series of IEC 61000 documents, as well as the norms EN50160 and IEEE 1159, shortly described and commented on, among others, in [1–3].

Many manufacturers offer instruments specifically designed to measure power quality parameters. Measurement results obtained with these devices, however, often vary during simultaneous measurements under the same conditions [4].

In Department Marine Electrical Power Engineering of Gdynia Maritime University, the instrument named “estimator/analyzer” (E/A), was designed. Its measurement functions are focused on

electrical power parameters designation, indication and registration. Also the registration of the raw samples of signals from electrical network for their further elaboration in external system, e.g. in the PC (Personal Computer) based reference system, is performed [5,6].

The fluency of operations concerning the acquisition of analog samples of signals from electrical power network depends on the synchronization of operations performed in measurement and registration track. During these operations the data are repeatedly converted and transmitted between functional blocks of instrument.

Ensuring the proper transmission of data (transmitted through signals), between devices or their functional blocks, requires synchronizing of the data receiver with the transmitter. Synchronization is the time coordination of at least two processes, namely the parallel pursuit them, independent from their course and coordinated in time. In other words, synchronization is the coordination of events to operate a system in harmony.

Many works concerning the nature, complexity and application aspects of the synchronization processes have been published last years [7–13].

Reviewing these papers, it should be noted that only some of them are dedicated to the general ideas and formal conditions of synchronization (e.g. [7]), but majority is concentrated on the application aspects of synchronization. Among numerous

* Corresponding author.

E-mail addresses: romas@am.gdynia.pl (R. Masnicki), j.mindykowski@we.am.gdynia.pl (J. Mindykowski).

publications belonging to latter category we can indicate a group of papers addressed to the distributed systems [8–11] and other one, related to real-time devices [12,13]. In [7], the authors have presented and discussed the formal conditions of synchronization, referring to Einstein's Special Theory of Relativity, to valuate the simultaneity of two events occurring at separate locations, considering the equivalence between simultaneity and synchronization.

Most of the papers discussing synchronization problems are focused on the distributed systems.

The ideas, related to the models of distributed systems clearly indicating the way of synchronization between specific devices, are analyzed in [8], where a key point is concentrated on the model of computation in distributed devices that is globally asynchronous, but locally synchronous. The design of a distributed system, as if all distributed components were driven by a perfect global clock, is addressed to the work on physically asynchronous architectures. By assuming one common notion of time, the distributed systems become logically synchronous.

In turn, in [9] the authors propose the portable hardware interface to synchronize the operations performed in the distributed, standalone measurement instruments, without the network service. The hardware interface clock is preliminarily synchronized with other hardware interfaces, including the compensation the clock signal phase, using the PC based synchronizing system. After synchronization procedure the hardware interface can bring the common sense of time to the distributed measurement instruments to coordinate their operations.

The paper [10] concerns the different measurement techniques to evaluate the time delay occurring among the synchronized node clocks, in respect to the reference clock, and by the arrival of the command at the synchronized node and the execution of the relative action.

In [11] the authors outline the synchronization requirements of future sensor networks and present an implementation of our own low power synchronization scheme, post-facto synchronization. There is also described an experiment that characterizes its performance for creating short-lived and localized but high precision synchronization using very little energy.

Some examples concerning the synchronization aspects in real-time devices described in [2] have been presented in [12,13].

The paper [12] presents a DSP-based hardware monitoring system based on a proposed power quality classification algorithm. The algorithm is optimized according to the architecture of the DSP to meet the real-time constraints of determining segment of signals in power systems.

In [13] the design and implementation of a high performance real-time power quality measuring instrument based on digital signal processor has been discussed. The synchronization issues considered in the paper are focused on of the device input signal sequence, by applying of the procedure of signal zero crossing detection and implementing of linear regression method for rebuilding the index position of the input samples zero crossing.

Recently in the literature the problem of synchronizing real-time operations performed in embedded systems is not discussed. This paper contains some considerations referring to the case-study, concerning instrument for analysis and estimation of electrical power system parameters, focused on the synchronization issues in the designed and constructed measurement track of real-time instrument.

Both data transmission and mutual cooperation between the blocks and the operations that make up the measuring channel must be coordinated. The typical digital measurement channel consists of functional blocks (Fig. 1) fulfilling established functions connected with processing of the data. After processing in selected block the data are sent to the next block.

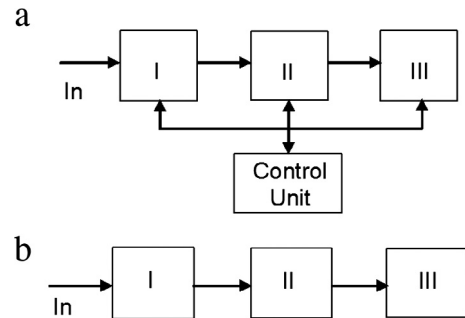

Fig. 1. The methods of synchronizing the operation in the digital measuring channel: (a) central, (b) distributed.

Fig. 1a shows the measuring circuit, in which the individual operations (or part thereof) are synchronized by a dedicated, central control unit (CCU). This unit, based on information about the status of individual operations, manages the operation of individual blocks of measuring circuit, synchronizes their cooperation. An example of a device, which operations in several blocks are coordinated in a manner as shown in Fig. 1a, is a digital storage oscilloscope (DSO). The CCU manages, among others, the selection of desired information from the data stream in the measuring system for displaying them on the DSO screen.

Fig. 1b illustrates the case of measuring circuits with distributed synchronization, wherein the interaction between the different functional blocks is based on the mutual synchronization of the simultaneously executed operations, directly exchanging the information. There is no master unit, coordinating the exchange of data between functional blocks connected in cascade. This type of process synchronization is the most widely used in measurement channels, especially where it is important for continuity and fluency of information stream processing and its registration. After data completion, as a consequence of data processing in selected functional block of instrument, the start of data transferring to the next functional block has to be coordinated between these blocks.

The transmission of data is usually carried out in synchronous mode, i.e. each data bit is sent under control of a timer of the data transmitter or data receiver. For connections between some functional blocks the coordination can be arranged synchronously, where the initiation of data sending is executed in synchrony with data sender operations, or asynchronously to them, in tact of data receiver operations.

The further part of this article focuses the attention on the measurement and registration track in which the synchronization between operations is organized in a distributed manner.

The main idea of the paper is to show and analyze the many aspects of the coordination operations, namely the synchronizations carried out in the track during the data transfer between functional blocks of the instrument for analysis and estimation of electrical parameters, documented by the case-study elaborated on real object investigation. An important issue of the considered case-study is concentrated on the differences in using the synchronous communication initiation, instead of asynchronous one, and consequences resulting from it.

The paper is organized in the manner, that after a short characteristics (in current Section 1) of the methods of synchronizing the operation in the digital measuring channel, the fluency conditions of data flow for selected configurations of the tracks for data registration are discussed and formulated in Section 2. Next three sections, i.e. 3, 4 and 5, respectively, are based on the analyzed case study, and concern the configuration of the E/A instrument dedicated to electrical power quality issues (Section 3) and a detailed

متن کامل مقاله

دریافت فوری ←

ISIArticles

مرجع مقالات تخصصی ایران

- ✓ امکان دانلود نسخه تمام متن مقالات انگلیسی
- ✓ امکان دانلود نسخه ترجمه شده مقالات
- ✓ پذیرش سفارش ترجمه تخصصی
- ✓ امکان جستجو در آرشیو جامعی از صدها موضوع و هزاران مقاله
- ✓ امکان دانلود رایگان ۲ صفحه اول هر مقاله
- ✓ امکان پرداخت اینترنتی با کلیه کارت های عضو شتاب
- ✓ دانلود فوری مقاله پس از پرداخت آنلاین
- ✓ پشتیبانی کامل خرید با بهره مندی از سیستم هوشمند رهگیری سفارشات