



Frequency support using doubly fed induction and reluctance wind turbine generators

A.B. Attya^a, S. Ademi^{b,*}, M. Jovanović^c, O. Anaya-Lara^d

^a Department of Engineering and Technology, University of Huddersfield, Huddersfield, UK

^b Warwick Manufacturing Group, University of Warwick, Coventry, UK

^c Faculty of Engineering and Environment, Northumbria University, Newcastle, UK

^d Department of Electronic and Electrical Engineering, University of Strathclyde, Glasgow, UK

ARTICLE INFO

Keywords:

Wind power
Doubly-fed machines
Ancillary services
Frequency stability
Virtual inertia

ABSTRACT

This paper presents the comparative computer simulations of a commercial doubly-fed induction generator (DFIG) and an emerging brushless doubly-fed reluctance generator (BDFRG) for grid-connected wind turbines in terms of frequency support based on the inertia emulation and blade pitching de-loading. The BDFRG features the low operation and maintenance cost by using a fractional inverter, and offers the high reliability of brushless structure with a simpler, more compact 2-stage gearbox design while still ensuring competitive performance to its popular slip-ring companion. The implemented benchmark is carefully designed to ascertain the relative capabilities of the two wind turbine generator technologies in providing this ancillary service. The results reveal that in spite of the fundamentally different operating principles, the DFIG and the BDFRG are highly aligned from the viewpoint of power system applications.

1. Introduction

The foreseen proliferation of distributed generation, and the accompanying disconnection of conventional power plants, might seriously threaten the power system voltage and frequency stability [1,2]. Consequently, TSOs have been updating the grid codes to incorporate the new demands from classical SGs and WFs, while the manufacturers of WTGs are competing to assure the compliance of their products with the latest grid integration regulations, including the ability to participate in the frequency regulation [3]. The reduced global inertia is a critical challenge for the system stability to face with the increasing penetration of WFs in large power networks or island grids [4,5]. To this extent, several control methods have been proposed with an incentive to allow the WTG to successfully tackle the frequency decay by imitating the inertia and primary responses of SGs in power stations [3,4]. Clear and well defined technical and legal rules and protocols are essential to avoid possible conflicts and malfunctions when such support methods are applied to large scale to ensure a smooth coordination between power systems and WFs during and shortly after frequency events [6].

This can be accomplished by maintaining a certain power reserve, or by releasing a portion of the stored KE in the WTG rotational parts [7]. The standard approaches taken are turbine blades pitching (e.g. de-

loaded operation), emulated KE extraction (i.e. synthetic inertia), and tip-speed control [8]. Alternative innovative strategies have also been devised and studied recently [9]. The effectiveness of all these procedures is contingent upon the WTG responses to sudden changes in WS and/or torque (power) reference stipulated by the controller to produce the aimed power surge and help curtail the incurred frequency fluctuations in the best possible manner. Quantitative metrics of frequency support capabilities of various WTGs and WFs using different methodologies have been put forward in [10].

Some recent work touched upon the impact of the controllers gains to provide pitch de-loading and virtual inertia. The study derived the root-loci and produced time simulations of a wide range of the involved controllers parameters (e.g. pitching system, torque control and frequency support) to investigate whether the control system stability was aligned to the improved performance of frequency response [11]. The main challenges facing de-loading and KE extraction are continuous curtailment of wind power and post-event recovery respectively. The amount of non-supplied energy due to de-loading techniques could be estimated according to the expected load curtailments. These curtailments will have an evident impact on frequency response as well as the financial aspects of system operation and dispatching. Simplified mathematical representation of the power system could be applied to calculate analytically the system inertia and available primary reserve

* Corresponding author.

E-mail address: s.ademi@warwick.ac.uk (S. Ademi).

Nomenclature

D_F	de-loading ratio
H_d	on-line inertia constant
$f_{drop_{max}}$	full support frequency threshold
f_{low}	frequency safe margin
f_o	nominal frequency
P_c	actual conventional generation in AC area
P_c^o	installed conventional generation in AC area
P_{WF}	wind farm generation
P_{ref}^o	active power reference
$T_{e,m}$	wind turbine electrical, mechanical torque
T_{gen}	conventional generation torque
T_{ref}^o	nominal reference torque
D_g, D_l	dynamic load model parameters
J	moment of inertia
K_{ex}	extraction factor

R	droop of aggregate generator
ΔP	power mismatch
BDFG	Brushless Doubly-Fed Generator
BDFIG	Brushless Doubly-Fed Induction Generator
BDFRG	Brushless Doubly-Fed Reluctance Generator
DFIG	Doubly-Fed Induction Generator
DFMs	Doubly-Fed Machines
KE	Kinetic Energy
MPT	Maximum Power Tracking
SGs	Synchronous Generators
RoCoF	Rate of Change of Frequency
TSOs	Transmission System Operators
WFs	Wind Farms
WS	Wind Speed
WTGs	Wind Turbine Generators

of WFs [12]. Meanwhile, the recovery stage (i.e. post frequency drops declared clear) could trigger further frequency drops, as the WTG output is suddenly reduced to start the recovery process, which is a key challenge of KE extraction. This could be mitigated by applying a pre-set shaping function with a ramp reduction in the WTG electrical output. The shaping function was triggered automatically independent of the drop severity when the frequency violated the safe deadband to initiate a step increase in the reference power signal of the WTG [13]. The technology and research challenges classification in considered six main categories of exploitation: frequency deadband, RoCoF, droop control, de-loading parameters, wind turbine level and wind farm-wide. However, the generator technology was not included which identify this area as a knowledge gap that could be tackled by this paper. The same reference has also presented the common designs of the supplementary controls used to apply the different concepts of frequency support, and their integrative approach to the holistic controls of the WTG [14].

The distinct advantages of high torque density, typically 30% rated power electronics, and inherently decoupled power control, have made the DFIG a widely adopted cost-effective solution for multi-MW wind turbines with restricted variable speed ranges (e.g. 2:1 or so) [15]. Nevertheless, the presence of brush gear unavoidably reduces its reliability raising the maintenance requirements, especially off-shore [16]. The BDFG overcomes the above DFIG drawbacks and has been regarded as a viable replacement. Unlike the DFIG, the BDFG has two ordinary, distributed 3-phase stator windings of different applied

frequencies and pole numbers, and a rotor with half the total number of stator poles for the shaft position dependent magnetic coupling to occur between the windings, a pre-requisite for the torque production. The rotor can be of special ‘nested-loop’ cage or wound structure (e.g. BDFIG) [17], featuring rather complicated and strongly parameter reliant control, or modern cage-less reluctance form (e.g. BDFRG) [18] allowing similar control simplifications of DFIG [15]. The primary (power) winding is directly grid connected, while the secondary (control) winding is supplied through a fractional dual-bridge converter in ‘back-to-back’ configuration for bi-directional power flow as with the DFIG (Fig. 1).

As the BDFG name reiterates, brushes and slip rings are eradicated, hence a more robust and maintenance-free construction. Besides, the BDFG is essentially a medium-speed machine, which renders the vulnerable high-speed stage of a three-step planetary DFIG gearbox redundant, enhancing the reliability and bringing further economic benefits [16]. These favorable properties are particularly appealing for off-shore WFs, where the DFIG running costs can be considerable [19]. Moreover, another salient BDFG merit to be pointed out is the distinguishing low-voltage-ride-through (LVRT) capability, which can be realised with much facilitated, or completely without, protective crowbar circuitry for the machine-side converter unlike the DFIG. Such attractive BDFG attributes have been afforded by the proportionally higher leakage inductances and lower fault current amplitudes than the equivalent DFIG having the well-known difficulties to fully satisfy the LVRT pertaining grid codes [19].

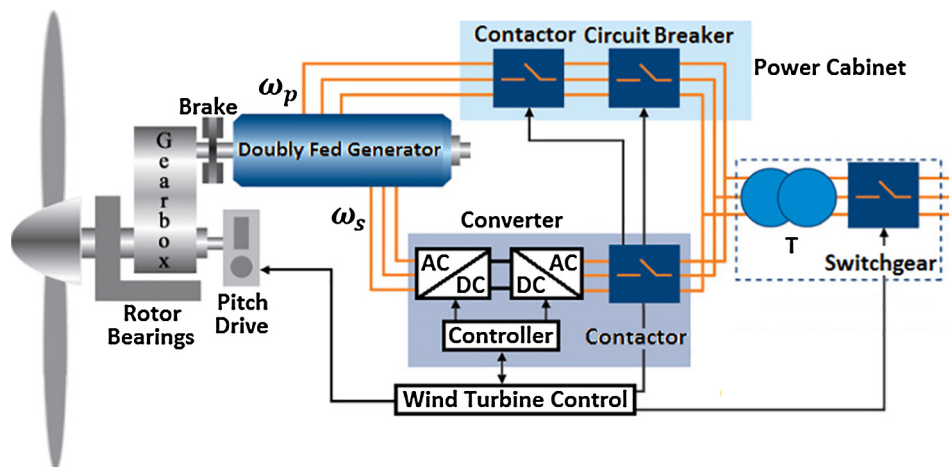

Fig. 1. A generic conceptual diagram of the BDFG and DFIG wind turbine for adjustable speed constant frequency grid-connected applications. (The control winding is on the stator for the BDFG, and on the rotor for the DFIG, but this is not detailed in the figure for convenience.)

متن کامل مقاله

دریافت فوری ←

ISIArticles

مرجع مقالات تخصصی ایران

- ✓ امکان دانلود نسخه تمام متن مقالات انگلیسی
- ✓ امکان دانلود نسخه ترجمه شده مقالات
- ✓ پذیرش سفارش ترجمه تخصصی
- ✓ امکان جستجو در آرشیو جامعی از صدها موضوع و هزاران مقاله
- ✓ امکان دانلود رایگان ۲ صفحه اول هر مقاله
- ✓ امکان پرداخت اینترنتی با کلیه کارت های عضو شتاب
- ✓ دانلود فوری مقاله پس از پرداخت آنلاین
- ✓ پشتیبانی کامل خرید با بهره مندی از سیستم هوشمند رهگیری سفارشات