



Contents lists available at ScienceDirect

## Journal of Food Engineering

journal homepage: [www.elsevier.com/locate/jfoodeng](http://www.elsevier.com/locate/jfoodeng)

## Food-grade double emulsions as effective fat replacers in meat systems

Viktorija Eisinaite<sup>a</sup>, Dovile Juraite<sup>a</sup>, Karin Schroën<sup>b</sup>, Daiva Leskauskaite<sup>a,\*</sup>

<sup>a</sup> Kaunas University of Technology, Department of Food Science and Technology, Radvilenu pl 19, Kaunas LT, 50254, Lithuania

<sup>b</sup> Wageningen University, Food Process Engineering Group, The Netherlands

### ARTICLE INFO

#### Article history:

Received 26 October 2016

Received in revised form

17 February 2017

Accepted 22 May 2017

Available online xxx

#### Keywords:

Double emulsion

Meat

Fat replacers

Encapsulation

### ABSTRACT

Double emulsions were used to not only replace 7 and 11% of animal fat in meat products, but also as a way to enhance the product colour. The coarse emulsion containing native beetroot juice as inner water phase, sunflower oil as oil phase and 0.5% whey protein isolate as outer water phase was prepared using a rotor stator system. The resulting coarse double emulsion had a typical average droplet size of 32  $\mu\text{m}$ , that was refined further using a hybrid membrane premix emulsification system resulting in an average droplet size of 20  $\mu\text{m}$ . Both double emulsions were exposed to heat treatment (70 °C for 30 min), and were physically stable due to the high viscosity (2.9 Pa s). Besides these emulsions had high colour retention. When added to meat systems, both double emulsions showed good water and fat binding capacity, and they reduced the hardness and improved the colour of meat systems, which are both desirable characteristics. The main conclusion of the paper is that double emulsion technology can be used to reach dual functionality in meat products; reduction of caloric load and colour retention.

© 2017 Elsevier Ltd. All rights reserved.

### 1. Introduction

Water-in-oil-in-water (W/O/W) emulsions, also known as double or multiple emulsions, are complex multiphase systems that consist of a water-in-oil emulsion dispersed in a second continuous water phase. The use of double emulsions in food products has recently been reviewed; therewith highlighting the promises that these emulsions hold for e.g. meat products (Jiménez-Colmenero, 2013). Cofrades et al. (2013) were the first to replace pork backfat in a meat system with W/O/W emulsion prepared with olive oil therewith reducing the amount of fat and improving the fatty acid profile. Basically, these authors used liquid emulsions as a technological strategy for the development of healthier meat products. In a follow up study in which frankfurters were used, part of the pork backfat was replaced with two different W/O/W emulsions containing perilla oil and pork backfat (Freire et al., 2015), and major fat reduction (over 60%) was achieved.

Although the application of double emulsions in meat products has clear advantages as described above, it also leads to loss of colour and low consumer acceptability of the products (Cofrades

et al., 2013). In order to circumvent this, encapsulation of red pigments in the inner water phase of double emulsions could be a promising route that is explored in this paper.

Nowadays natural red pigments, such as carotenoids, anthocyanins and betalains, are preferred as food colourants. Red beet root powder (Elbe et al., 1974), red yeast rice powder (Martínez et al., 2006), wheat fibre colored with a safflower (Hyun-Wook et al., 2015), colourants extracted from red *Amaranthus* (Zhou et al., 2012) have been used to simulate cured meat colour in cooked, smoked, semidry and fermented sausages. However, many of these colourants are sensitive to environmental conditions such as basic or very acidic pH, light, and oxygen. Using the inner water phase of the W/O/W emulsions for encapsulation of the colourant could isolate them from the detrimental surrounding aqueous environment. In order to achieve this, a stable formulation needs to be developed for which the type of oil, emulsifier, and encapsulated material are all relevant (Su et al., 2006, 2008).

Interesting colourants are beetroot betalains that have been encapsulated in W/O/W emulsions, leading to stable pink-colored double emulsions (Kaimainen et al., 2015). In previous work, we used a hybrid premix emulsification system to prepare considerable amounts of such beetroot juice loaded double emulsions (Eisinaite et al., 2016), and found them highly stable due to their high viscosity. This now opens the way to application in actual food

\* Corresponding author.

E-mail addresses: [viktorija.eisinaite@ktu.lt](mailto:viktorija.eisinaite@ktu.lt) (V. Eisinaite), [karin.schroen@wur.nl](mailto:karin.schroen@wur.nl) (K. Schroën), [daiva.leskauskaite@ktu.lt](mailto:daiva.leskauskaite@ktu.lt) (D. Leskauskaite).

### Abbreviations

W/O/W	double water-in-oil-in-water emulsion
W1/O	primary water-in-oil emulsion
PGPR	polyglycerol polyricinoleate
WPI	whey protein isolate
DE-C	coarse double emulsion
DE-F	fine double emulsion
MS-C-7	meat system, containing 7% of pork backfat
MS-C-11	meat system, containing 11% of pork backfat
MS-DE-C-7	meat system, containing 7% of fat through addition of coarse double emulsion
MS-DE-C-11	meat system, containing 11% of fat through addition of coarse double emulsion
MS-DE-F-7	meat system, containing 7% of fat through addition of fine double emulsion
MS-DE-F-11	meat system, containing 11% of fat through addition of fine double emulsion
TFR	total fluid released
WR	water released
FR	fat released

products; in this paper we choose to work with meat products.

In this paper, we investigate whether W/O/W emulsion can be used to reduce the caloric load of sausages, and to improve their colour making use of the intrinsic options that double emulsions offer. The internal water phase replaces part of the fat and thus reduces the amount of calories, while at the same time it serves as a protective area for the colourant. We made W/O/W emulsions, containing beetroot juice in the inner water phase, sunflower oil as the oil phase, and as emulsifiers we chose to work with polyglycerol polyricinoleate (W/O interface) and whey protein (O/W interface). For emulsification we used standard and novel techniques, and monitored various characteristics of the double emulsions, and the meat products to which they were added (also after heat treatment), such as colour, water and fat binding capacity, and textural properties.

## 2. Materials and methods

### 2.1. Materials

MilliQ ultra-pure water (Milli-Q Integral Water Purification Systems, Darmstadt, Germany) was used for the preparation of the emulsion's aqueous phases. Sunflower oil was purchased from a local supermarket (Wageningen, The Netherlands). Beetroots used for juice preparation were bought in a local Lithuanian supermarket (Kaunas, Lithuania). Polyglycerol polyricinoleate (PGPR) was used as received from Danisco (Copenhagen, Denmark) and applied as oil soluble emulsifier. Whey protein isolate (WPI) (Lacprodan DI-9213) was used as water soluble emulsifier (Arla Foods Ingredients Group (Viby, Denmark). It contained  $89.7 \pm 0.3\%$  protein,  $6.0 \pm 0.1\%$  moisture,  $4.0 \pm 0.1\%$  ash,  $0.2\%$  fat, and  $0.1\%$  lactose. For meat systems preparation fresh post-rigor raw pork was obtained from a local supermarket (Wageningen, The Netherlands) and sodium chloride was used ( $\geq 99\%$ , ReagentPlus, Sigma-Aldrich Co. LLC, St.Louis, USA). All components were food-grade.

#### 2.1.1. Freeze – dried beetroot juice preparation

Beetroot juice was made as follows. Beetroots were washed, cut into pieces and run through a low-speed press Zelmer JP 1500

(Warszawa, Poland), centrifuged at 3000 rpm for 10 min (Sorvall legend XFR, Thermo Scientific, Vantaa, Finland) and filtered. The colour of the juice was ( $L^* 23.5$ ,  $a^* 2.6$ ,  $b^* -0.5$ ); the pH 6.3, and Brix 8.5%. Juice with no particles was frozen at  $-18^\circ\text{C}$ , and lyophilized using a freeze-drying unit (Sublimator  $3 \times 4 \times 5$  Zirbus technology, Bad Grund, Germany). The temperature in the condenser of the freeze-drying unit was  $-45^\circ\text{C}$ .

#### 2.1.2. Coarse W/O/W emulsion (premix) preparation

The coarse double emulsions (DE-C) were prepared following a two-step emulsification process with an Ultra-Turrax rotor stator system (IKA® T-18 basic, Staufen, Germany). The inner water phase ( $W_1$ ) consisted of rehydrated freeze-dried beetroot juice (ratio of beetroot powder and distilled water was 1:9). An oil phase (O) was prepared by dispersing 6% PGPR in sunflower oil and mixing it on a magnetic stirrer at  $50^\circ\text{C}$  for 15 min. For the outer water phase, 0.5 g of WPI was mixed with the 99.5 g of distilled water on the magnetic stirrer until dissolved to obtain 0.5% WPI solution ( $W_2$ ). The pH of this solution was 6.8. The primary emulsion  $W_1/O$  was prepared by drop wise addition of  $W_1$  to the oil phase (ratio of water to oil was 20:80) and homogenised with the Ultra-Turrax at  $50^\circ\text{C}$  for 15 min at 15.000 rpm speed. To avoid heating of the product, an ice bath was used, and temperature was monitored continuously ( $50^\circ\text{C} \pm 3^\circ\text{C}$ ) during the homogenisation process. The primary emulsion was cooled to room temperature before further use. Finally, the coarse double emulsion was prepared by adding primary emulsion ( $W_1/O$ ) to the outer water phase ( $W_2$ ) at ratio 40:60, and homogenised with an Ultra-Turrax at lower speed (11.000 rpm) for 5 min at room temperature.

#### 2.1.3. Fine W/O/W emulsion preparation

The fine double emulsion (DE-F) was prepared by using the hybrid premix membrane emulsification system described in earlier research (Eisinaite et al., 2016). Such system consist of the pressure vessel connected to an air supply, and a packed bed module (schematic representation in the Fig. 1). The packed bed of glass beads is mounted on a nickel sieve, which was placed at the bottom of a stainless steel column where it served as a support for the hydrophilic glass beads layer placed on it (built by the mechanical workshop of Wageningen University). For the experiment the bed of glass beads ( $d_{32} \approx 71$ ) was 2 mm high. Briefly, the previously prepared coarse emulsion was once pushed through the packed bed module at constant pressure – 300 kPa. The homogenised fine emulsion was collected in a vessel that was placed on an electric balance and used for further experiments.

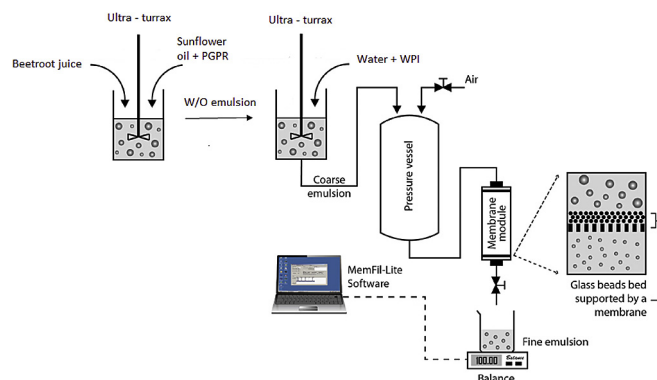

Fig. 1. Schematic representation of the experimental set-up and emulsification procedure [adapted from Nazir et al., (2014)].

متن کامل مقاله

دریافت فوری ←

**ISI**Articles

مرجع مقالات تخصصی ایران

- ✓ امکان دانلود نسخه تمام متن مقالات انگلیسی
- ✓ امکان دانلود نسخه ترجمه شده مقالات
- ✓ پذیرش سفارش ترجمه تخصصی
- ✓ امکان جستجو در آرشیو جامعی از صدها موضوع و هزاران مقاله
- ✓ امکان دانلود رایگان ۲ صفحه اول هر مقاله
- ✓ امکان پرداخت اینترنتی با کلیه کارت های عضو شتاب
- ✓ دانلود فوری مقاله پس از پرداخت آنلاین
- ✓ پشتیبانی کامل خرید با بهره مندی از سیستم هوشمند رهگیری سفارشات