



Emitter/receiver piezoelectric films coupled to flow-batch analyzer for acoustic determination of free glycerol in biodiesel without chemicals/external pretreatment

Gabriel M. Eggly^a, Matías Blackhall^a, Adriano de Araújo Gomes^b, Rodrigo Santos^a, Mário César Ugulino de Araújo^c, Marcelo F. Pistonesi^{d,*}

^a Dep. Ingeniería Eléctrica y de Computadoras, Universidad Nacional del Sur, IIIE-CONICET, Av. Alem 1253 (B8000CPB), Bahía Blanca, Buenos Aires, Argentina

^b Departamento de Química Inorgânica – DQI, Instituto de Química – IQ, Universidade Federal do Rio Grande do Sul, Instituto de Química-UFRGS, Av. Bento Gonçalves 9500 Agronomia 91501970 - Porto Alegre, RS - Brasil

^c Universidade Federal da Paraíba, Dep. de Química, Laboratório de Automação e Instrumentação em Química Analítica/Quimiometria (LAQA), Caixa Postal 5093, 58051-970 João Pessoa, PB, Brazil

^d Dep. de Química, Universidad Nacional del Sur, INQUISUR, Av. Alem 1253 (B8000CPB), Bahía Blanca, Buenos Aires, Argentina

ARTICLE INFO

Article history:

Received 13 October 2017

Received in revised form 12 January 2018

Accepted 17 January 2018

Available online xxxx

Keywords:

Flow-batch
Piezoelectrics
PLS models
Biodiesel
Glycerol

ABSTRACT

This paper describes for the first time the use of emitter and receiver piezoelectric films coupled one in front of the other into a flow-batch analyzer for acoustic determination of free glycerol in biodiesel without chemicals/external pretreatment. Online extraction of free glycerol from biodiesel was carried out into aqueous solution without chemicals/external pretreatment. While the emitter piezoelectric is activated to sonicate the solution, the receiver piezoelectric translates the acoustic signal received into an electrical signal, which is measured and recorded by a digital oscilloscope. Multivariate calibration models were built for prediction of free glycerol concentration. In this sense, results of partial least square regression (PLS), the interval PLS (iPLS) and PLS coupled with the Successive Projections Algorithm for interval selection (iSPA-PLS) were compared. The proposed low-cost flow-batch analyzer exhibited good performance, satisfactory detection limit (0.12 mg kg⁻¹) and a linear response from 72 to 372 mg kg⁻¹ of free glycerol in biodiesel. The procedure was successfully applied to the analysis of biodiesel samples, and the results agreed with the reference method (ASTM D6584-07) at 95% confidence level.

© 2018 Elsevier B.V. All rights reserved.

1. Introduction

Biodiesel is a great substitute for petroleum diesel that can be used on any unmodified diesel engine. It has important characteristics that make it attractive since it is a renewable, non-toxic, biodegradable and ecofriendly fuel [1]. Blends of biodiesel and diesel are the most commonly products distributed for use in the retail biofuel marketplace. However, the biodiesel manufacturing process generates approximately 10% (w/w) of glycerol as the sub-product main [2–3]. Since glycerol is slightly soluble in esters (biodiesel), glycerol present in biodiesel causes negative effects on the diesel engine, such as clogging fuel filters, fouling fuel injectors, and forming a deposit on the bottom of fuel storage tanks [4–6]. In order to minimize the problems caused by glycerol, sustain production of biofuels, and provide quality control criteria to this developing industry, ASTM and other regulatory organizations have established limits of 0.02% (w/w) for free glycerol [7]. Therefore, accurate and sensitive methods are needed for the determination of free and total glycerol

in biodiesel. Several methods for determining free glycerol content in biodiesel have been developed based on chromatographic [8–9], amperometric [10], and spectrophotometric techniques [11–13]. Also, sonoluminescent flow-batch method to determine free glycerol in biodiesel was proposed by Diniz et al. [14]. In this work, water was used to generate water-cavitation sonoluminescence signals, which were modulated by the quenching effect associated with the amount of free glycerol. The method requires the use of a photomultiplier tube (PMT) as detector that needs a stabilized high voltage power supply to achieve a reasonable sensitivity and noise immunity. The generation of the water-cavitation signal was achieved using a ceramic piezoelectric device. The use of piezoelectric technology has been increased significantly in recent years. It can be used both as sensor or actuator based on its capability as a transducer device [15–17]. Like every transducer, it converts one form of energy into another (in this case, mechanical into electrical and vice-versa). It produces voltage or charge proportional in both amplitude and frequency to an applied dynamic strain [18]. In 1969, Kawai found very high piezo-activity in the polarized fluoropolymer, polyvinylidene fluoride (PVDF) [19]. New copolymers of PVDF, developed over the last few years, have expanded the applications of

* Corresponding author.

E-mail address: mpistone@criba.edu.ar (M.F. Pistonesi).

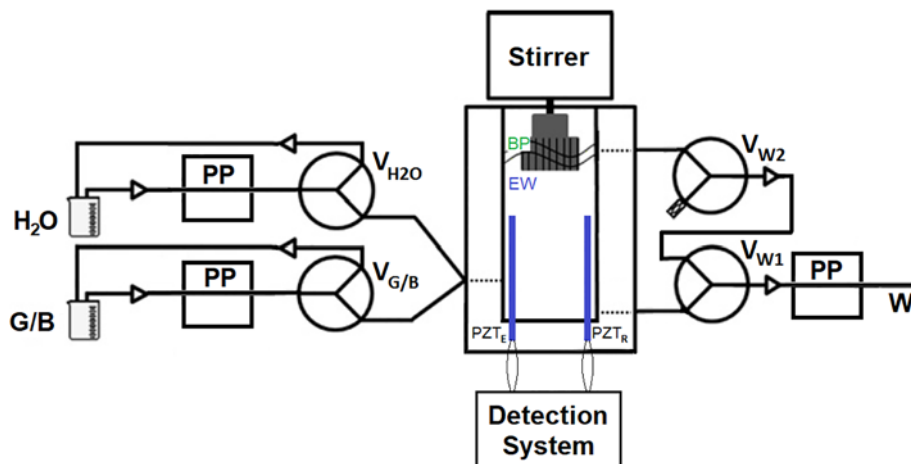

Fig. 1. Schematic diagram of the flow-batch analyzer. Three-way solenoid valves (V), lab-made peristaltic pump (PP), biodiesel phase (BP), extractive water (EW), emitter (PZT_E) and receiver (PZT_R) piezoelectric films, waste (W), glycerol standard solution or biodiesel sample (G/B).

piezoelectric polymer sensors [20–21]. One major advantage of piezoelectric film over piezoelectric ceramic is its low acoustic impedance, which is closer to that of water, human tissue and other organic materials [22]. Although piezoelectric film has low density and excellent sensitivity, and it is mechanically tough. Additionally, when extruded into thin film, piezoelectric polymers can be directly attached to a structure without disturbing its mechanical motion [23]. The demand of these sensors has been propelled by the growth in the use of microcontrollers. Diverse

applications in the field of chemistry could be found in the literature [24–26].

This paper describes for the first time the use of emitter (PZT_E) and receiver (PZT_R) piezoelectric films coupled one in front of the other into a flow-batch analyzer for acoustic determination of free glycerol in biodiesel without chemicals/external pretreatment. While PZT_E is activated to sonicate, PZT_R translates the acoustic signal received into an electrical signal, which is measured by the data acquisition system.

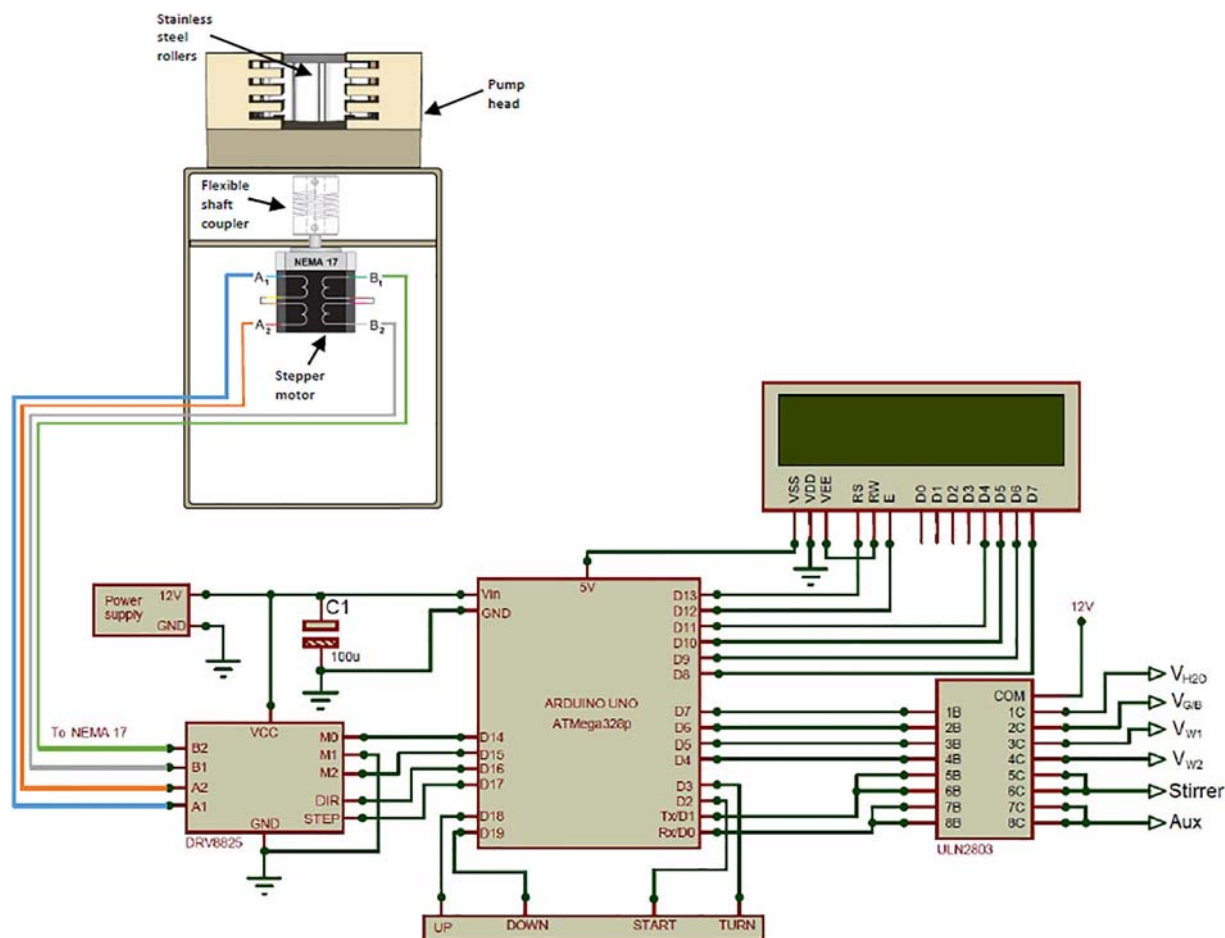

Fig. 2. Lab-made peristaltic pump coupled to the schematic circuit of the flow-batch analyzer controller unit.

متن کامل مقاله

دریافت فوری ←

ISIArticles

مرجع مقالات تخصصی ایران

- ✓ امکان دانلود نسخه تمام متن مقالات انگلیسی
- ✓ امکان دانلود نسخه ترجمه شده مقالات
- ✓ پذیرش سفارش ترجمه تخصصی
- ✓ امکان جستجو در آرشیو جامعی از صدها موضوع و هزاران مقاله
- ✓ امکان دانلود رایگان ۲ صفحه اول هر مقاله
- ✓ امکان پرداخت اینترنتی با کلیه کارت های عضو شتاب
- ✓ دانلود فوری مقاله پس از پرداخت آنلاین
- ✓ پشتیبانی کامل خرید با بهره مندی از سیستم هوشمند رهگیری سفارشات