



# Performance analysis of an integrated gas-, steam- and organic fluid-cycle thermal power plant



C.O.C. Oko\*, I.H. Njoku

Department of Mechanical Engineering, Faculty of Engineering, University of Port Harcourt, Port Harcourt, Nigeria

## ARTICLE INFO

### Article history:

Received 28 September 2016

Received in revised form

14 January 2017

Accepted 20 January 2017

Available online 23 January 2017

### Keywords:

Integrated power generation

Combined cycle power plant

Organic Rankine cycle

Exergy analysis

Organic fluids

Waste-to-energy conversion

## ABSTRACT

This paper presents the performance analysis of an existing combined cycle power plant augmented with a waste heat fired organic Rankine cycle power plant for extra power generation. This was achieved by performing energy and exergy analysis of the integrated gas-, steam- and organic fluid-cycle thermal power plant (IPP). Heat source for the subcritical organic Rankine cycle (ORC) was the exhaust flue gases from the heat recovery steam generators of a 650 MW natural gas fired combined cycle power plant. The results showed that extra 12.4 MW of electricity was generated from the attached ORC unit using HFE7100 as working fluid. To select ORC working fluid, ten isentropic fluids were screened and HFE7100 produced the highest net power output and cycle efficiency. Exergy and energy efficiencies of the IPP improved by 1.95% and 1.93%, respectively. The rate of exergy destruction in the existing combined cycle plant was highest in the combustion chamber, 59%, whereas in the ORC, the highest rate of exergy destruction occurred in the evaporator, 62%. Simulations showed exergy efficiency of the IPP decreased with increasing ambient temperature. Exit stack flue gas temperature reduced from 126 °C in the combined cycle power plant to 100 °C in the integrated power plant.

© 2017 Published by Elsevier Ltd.

## 1. Introduction

With the increasing global demand for electric power, it is imperative to sustain efforts at improving power generation technologies with high energy conversion efficiencies. The combined cycle power plant (CCPP), though, an improvement over the single cycle power plant could be discharging usable low grade waste heat [1]. Several studies have focused on the performance analysis and performance enhancement of combined cycle power plant using various technologies. Mohapatra [2] compared the impact of integrating vapor compression and vapor absorption cooling systems to a combined cycle plant for inlet air cooling. Their study showed that inlet air cooling using the vapor compression refrigeration system improved the plant's specific power output by 9.02% compared to 6.09% obtained with the vapor absorption cooling. However to operate the vapor compression system, power is extracted from the gas turbine output. Boonnasa et al. [3] in their study integrated a steam operated absorption chiller to a CCPP for the compressor inlet air cooling. In cooling the gas turbine (GT) compressor inlet air,

the GT power output increased by about 10.6% for the GT and 6.24% for the CCPP, though the power output of the steam turbine (ST) was decreased by about 2.43% due to the steam extracted to operate the absorption chiller.

Gadhamshetty et al. [4] and Nirmalakhandan et al. [5] proposed the integration of a chilled-water thermal energy storage (TES) system to pre-cool the inlet air to the air cooled steam condenser (ACC) of the CCPP. The temperature of the TES system was maintained by an absorption refrigeration system (ARS) driven by waste heat from the flue gases of the CCPP. Though this system presented overall plant improvement, the major concern with was the large volume of the storage tank, which is a function of plant capacity, the design inlet air temperature to ACC, and waste heat recovery efficiency from the stack gases. The analysis showed that a minimum recovery efficiency of 80% would be necessary for optimal sizing of the TES tank. At lower waste heat recovery efficiency values, the TES tank volume increased rapidly rendering the system impractical.

Statistical investigations indicate that the low-grade waste heat accounts for 50% or more of the total heat generated in industries [6,7]. Due to the lack of efficient recovery technologies, a lot of the low-grade energy is merely discarded. At present, however, the low-grade thermal energy may be converted into useful energy

\* Corresponding author.

E-mail address: [chika.oko@uniport.edu.ng](mailto:chika.oko@uniport.edu.ng) (C.O.C. Oko).

through absorption refrigeration cycle or through organic fluid power cycle which is the organic Rankine cycle. The organic Rankine cycle (ORC) is similar to the conventional steam Rankine cycle, but uses an organic fluid such as refrigerants and hydrocarbons, instead of water as the working fluid and appears as a promising technology for the conversion of low grade heat into useful work and electricity [6–11]. The thermal energy source temperature for ORC can vary from 80 °C to over 250 °C using appropriate working fluid [8,10]. In fact, the ORC technology is now very popular for low-grade energy-to power conversion especially in the use of renewable energy sources and waste heat recovery from thermal processes [9].

In practice, the basic subcritical ORC configuration (without regeneration), in which saturated or slightly superheated vapor is expanded in a turbine, is often used for waste heat to power applications [7]. Although introduction of regeneration increases the cycle efficiency of ORC, this is not justified in waste heat to power applications, for which the power output should be maximized instead of the cycle efficiency [6,12]. Studies show that isentropic organic fluids are most suitable for low temperature waste heat applications in order to avoid liquid droplet impingement in the turbine blades during the expansion process [8,12,13]. Therefore, this paper presents the performance analysis of an integrated gas-, steam- and an organic fluid-cycle thermal power plant, which operates on a single thermal energy source (the natural gas supplied to the combustion chamber of the gas turbine cycle). A subcritical organic Rankine cycle is integrated to an existing 650 MW combined cycle power plant operating in Southern Nigeria to increase the overall plant power output, efficiency and thus reduce the exit flue gas temperature. To select an organic working fluid, ten organic working fluids were screened in the Engineering Equation Solver (EES) environment and the entire integrated system is analyzed thermodynamically using the energy and exergy methods.

## 2. Problem formulation and solution methods

The integrated power plant configuration and operating description are presented in this section. The mathematical equations for the performance analysis are also presented.

### 2.1. System description

The multi-shaft combined thermal power plant consists of: three natural gas fired gas turbine (GT) units; three dual pressure, forced circulation heat recovery steam generators (HRSG); a dual pressure steam turbine (ST) unit with one high pressure and two low pressure double flow casings; air cooled condenser unit and two feed water pumps—high and low pressures. The schematic and phase diagrams of the integrated gas-, steam-, and organic fluid-cycle thermal power plants are shown in Figs. 1 and 2.

In the combined cycle power plant, inlet air at the ambient temperature (state 1) is compressed by the air compressor (AC) to state 2 before entering the combustion chamber (CC) where it mixes with the natural gas from the fuel supply system to produce hot flue gases, which exit the CC and enters the gas turbine (GT). The flue gases expand in the GT from state 3 to state 4, producing power for driving the compressor and for conversion into electricity. The exhaust flue gases at state 4 pass through the heat recovery steam generator (HRSG) where high and low pressure feed water streams are heated to states 7 and 8, respectively, as the flue gases exit the HPHRSG and LPHRSG at states 5 and 6 respectively. The superheated steam from the HPHRSG at state 7 expands in the high pressure turbine (HPST) to state 8, and mixes with the superheated steam from the LPHRSG at state 9 to form a homogenous

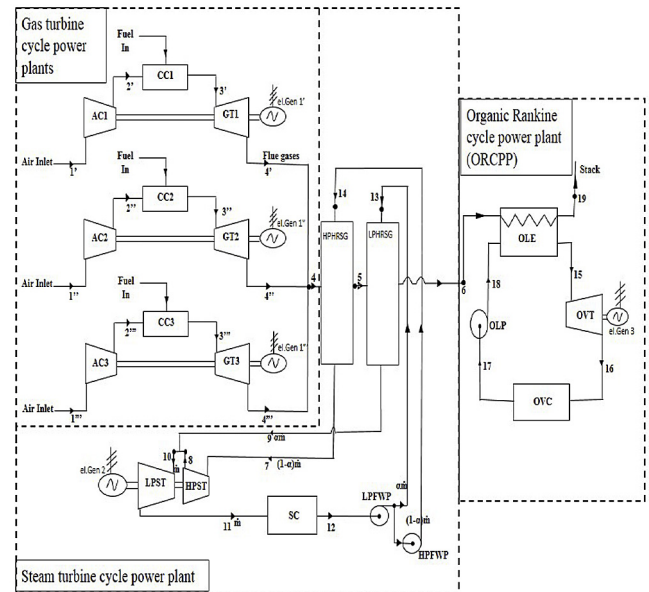

Fig. 1. Schematic diagram of the integrated gas-, steam-, and organic fluid-turbine cycle power plant.

steam mixture at state 10 before expanding in the low pressure steam turbine (LPST) to state 11; The mechanical power from the steam turbines is converted into electrical power in the electrical generator 2 (el.Gen 2). The exit wet steam is condensed in the steam condenser (SC) to saturated liquid water at state 12 before pumped by the low pressure feed water pump (LPFWP) to state 13. One part of this low pressure feed water ( $\alpha\dot{m}$ ) is fed into the LPHRSG, while the remaining part ( $(1-\alpha)\dot{m}$ ) is pumped by the high pressure water pump (HPFWP) to state 14 and fed into the HPHRSG for the dual-pressure steam turbine cyclic process to continue repeating.

An organic Rankine cycle power plant (ORCPP) is integrated into the CCP just described, in order to extract additional useful energy from the exhaust flue gases at state 6. Here, an appropriately chosen organic fluid is evaporated in the organic liquid evaporator (OLE) to a saturated vapor at state 15 by the exhaust flue gases, which are cooled down to state 19 before being exhausted into the atmosphere. The organic vapor is expanded in the organic vapor turbine (OVT) to state 16 to produce additional electric power in the electric generator (el.Gen 3). The wet organic fluid is condensed in the organic vapor condenser (OVC) to state 17 and subsequently pumped by the organic liquid feed pump (OLFP) to state 18, and fed in to the OLE to continue repeating the cyclic process.

### 2.2. Performance analysis of the combined cycle power plant

The performance analysis is required to determine the thermodynamic properties of the working fluids of the plant at various states, the energy and exergy characteristics of the system.

The assumptions made in the analysis are:

- Mass, energy and exergy flows through the plant are steady state.
- Changes in kinetic and potential forms of energy and exergy are negligibly small.
- All gases (air and flue gases) behave like ideal gases.
- Thermal and mechanical energy losses are negligibly small.

متن کامل مقاله

دریافت فوری ←

**ISI**Articles

مرجع مقالات تخصصی ایران

- ✓ امکان دانلود نسخه تمام متن مقالات انگلیسی
- ✓ امکان دانلود نسخه ترجمه شده مقالات
- ✓ پذیرش سفارش ترجمه تخصصی
- ✓ امکان جستجو در آرشیو جامعی از صدها موضوع و هزاران مقاله
- ✓ امکان دانلود رایگان ۲ صفحه اول هر مقاله
- ✓ امکان پرداخت اینترنتی با کلیه کارت های عضو شتاب
- ✓ دانلود فوری مقاله پس از پرداخت آنلاین
- ✓ پشتیبانی کامل خرید با بهره مندی از سیستم هوشمند رهگیری سفارشات