

# A proposed advanced maximum power point tracking control for a photovoltaic-solar pump system



Mohamed Fawzy El-Khatib<sup>a,b</sup>, S. Shaaban<sup>a,\*</sup>, Mohamed I. Abu El-Sebah<sup>a,c</sup>

<sup>a</sup> Mechanical Engineering Department, College of Engineering and Technology-Cairo Campus, Arab Academy for Science, Technology and Maritime Transport (AASTMT), Cairo, Egypt

<sup>b</sup> Mechatronics and Robotics Engineering Department, Faculty of Engineering, Egyptian Russian University (ERU), Badr, Egypt

<sup>c</sup> Electronics Research Institute, Cairo, Egypt

## ARTICLE INFO

### Keywords:

Photovoltaic  
MPPT  
SUI-PID controller  
Solar pump

## ABSTRACT

The maximum power point tracking (MPPT) for a photovoltaic (PV) system using the conventional methods suffers from being slow or inaccurate during sudden changes in irradiance and temperature. Artificial intelligent algorithms can overcome these drawbacks. However, these algorithms have high complexity in the design and implementation. Thus, the present work applies a Simplified Universal Intelligent PID Controller (SUI-PID) to extract the maximum power from a photovoltaic system with a solar pump as the load. The proposed SUI-PID controller was compared to the Fuzzy logic controller (FLC) under different operating conditions. The MATLAB/Simulink software package was utilized for the system simulation. Simulation results show that the proposed SUI-PID controller has 32.7% faster response with better rise time compare to the FLC. The SUI-PID controller offers additional advantages like the simplicity in design and implementation compared to other intelligent algorithms.

## 1. Introduction

Photovoltaic systems (PV) are very important for the conversion of the clean and sustainable solar energy into electricity. The conversion efficiency of the photovoltaic system is in the range of 10:20%, depending on its type (Liu et al., 2016). Moreover, this efficiency range can be further dropped by decreasing the irradiance, increasing the panel temperature, and varying the load conditions (Bendib et al., 2015). Due to the low efficiency of the PV system and its non-linear I-V characteristics under different operating conditions, it was necessary to apply a maximum power point tracking control (MPPT). The MPPT control ensures that the PV panel produces the maximum possible power under different loads and operating conditions (Liu et al., 2016; Bendib et al., 2015; Garraoui et al., 2015). Solar pumps can be connected to PV panels in order to provide water for irrigation and drinking (Hadjaissa et al., 2016; Yadav et al., 2015). It is always desired to submit the pump with the maximum possible power under different operating conditions. Therefore, a MPPT control was investigated in the present work for a solar pump powered by a PV panel.

According to Thevenin's theorem, the PV resistance must equal the load resistance in order to deliver the maximum PV panel power to the load. This can be achieved by using a dc-dc converter located between

the PV system and the load. This converter changes the operating point of the PV system until it reaches the maximum power point (MPP) (Kermadi and Berkouk, 2017; Prasanth and Rajasekar, 2017). The aim of the different maximum power point tracking (MPPT) methods is to produce a suitable duty cycle pulse to the converter in order to move the operating point towards the MPP. Thus, the value of the load on the PV system will be almost equal to the optimum load under the different operating conditions. Hence, the maximum power delivery condition is satisfied and the optimum conversion efficiency could be reached (Mohammed et al., 2016; Kichou et al., 2016). Tracking the MPP can be achieved using conventional methods or intelligent algorithms. The conventional methods include the incremental conductance method, fractional open-circuit voltage, fractional short-circuit current, and perturb and observe method. These methods use a fixed step to get the optimal value of the duty cycle which may cause wrong or slow tracking during sudden changes in temperature or irradiance. The intelligent algorithms include the fuzzy logics, neural networks, and neuro-fuzzy. These algorithms implement a variable step to get the optimal value of the duty cycle and hence results in a faster time response and more stability under varying operating conditions. However, the intelligent algorithms have certain degree of complexity in the design and implementation (Mohammed et al., 2016; Kichou et al.,

\* Corresponding author.

E-mail addresses: [Muhamed-fawzy@eru.edu.eg](mailto:Muhamed-fawzy@eru.edu.eg) (M. Fawzy El-Khatib), [Sameh.Shaaban@aast.edu](mailto:Sameh.Shaaban@aast.edu) (S. Shaaban), [Mohamedibrah32@aast.edu](mailto:Mohamedibrah32@aast.edu) (M.I. Abu El-Sebah).

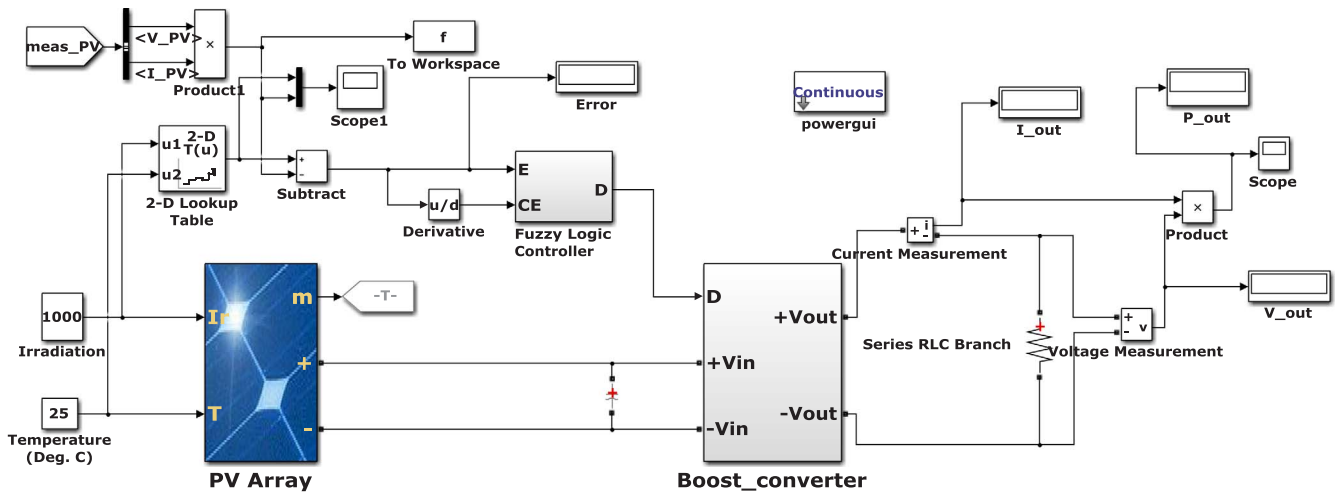

Fig. 1. Simulation model of the PV system with Fuzzy logic controller.

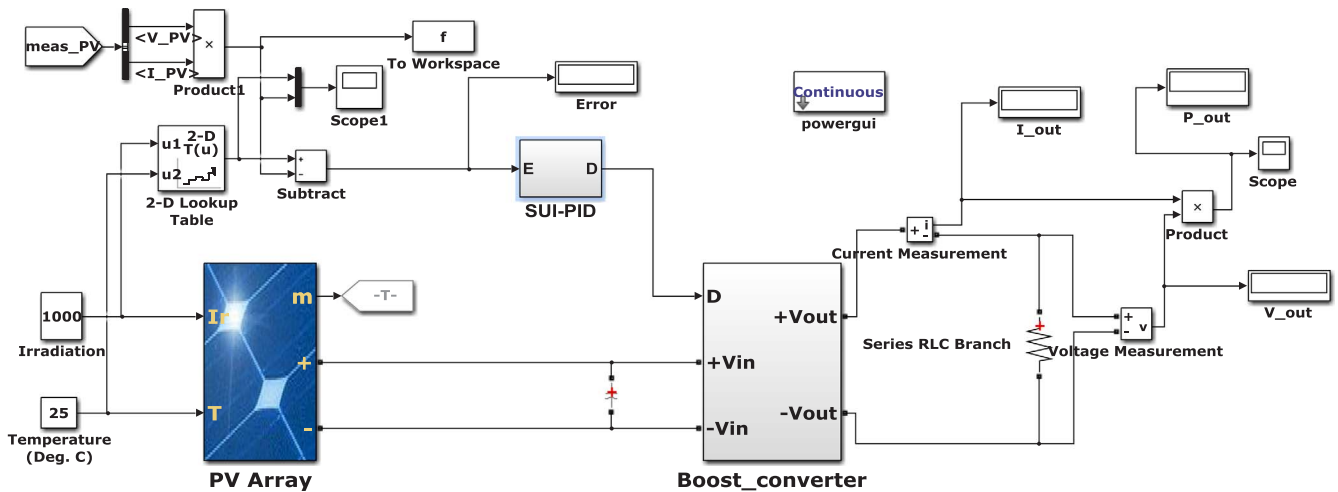

Fig. 2. Simulation model of the PV system with SUI-PID controller.

Table 1  
Electrical parameters of the experimental module of Chao et al. (Chao et al. (2012)).

Designation	Value
Maximum power (PMPP)	75 W
Voltage at $P_{max}$ (VMPP)	17 V
Current at $P_{max}$ (IMPP)	4.4 A
Open-circuit-voltage ( $V_{OC}$ )	21.7 V
Short-circuit-current ( $I_{SC}$ )	4.8 A
Temperature coefficient: open-circuit voltage	-0.077 V/°C
Temperature coefficient: short-circuit current	2.06 mA/°C

2016; Al-Gizi, 2016; Daraban et al., 2014; Subiyanto et al., 2012; Dounis et al., 2013; Bendib et al., 2014; Abu El-Sebah, 2016). Thus, the purpose of the present work is to apply the SUI-PID controller for the MPPT due to its simplicity and intelligence (Abu El-Sebah, 2016, 2010). The SUI-PID controller is considered a simplified controller due to its

ability to use simple design algorithm and modeling technique that doesn't require the calculation of the PID controller constants like the regular PID controller. Moreover, an estimation of the system transfer function is not required with the application of the SUI-PID controller. It is classified as an intelligent controller due to its self-adaptation of the controller constants during the system operation. Details of the SUI-PID controller will be discussed in Section 5. The results of the proposed SUI-PID control were compared with the Fuzzy Logic Controller (FLC) to test and evaluate the performance of the new algorithm under uniform irradiance and sudden changes in irradiance levels. The performance of the solar pump was also evaluated with the two controllers as well as without control. Both algorithms were simulated using the MATLAB-Simulink with PV module BP SX 150S and under dc pumping load.

The present paper will be organized as follows, Section 2 presents a validation of the proposed simulation model while Section 3 introduces

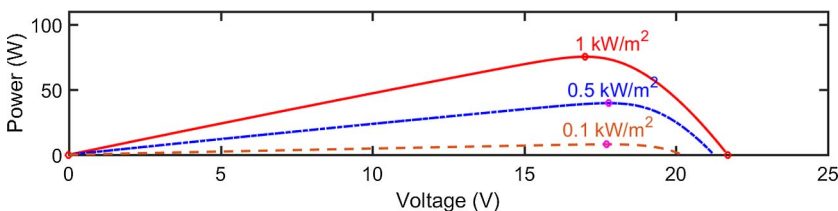

Fig. 3. P-V characteristic under different irradiance values and constant temperature  $T = 25\text{ }^{\circ}\text{C}$  (75 W module).

متن کامل مقاله

دریافت فوری ←

**ISI**Articles

مرجع مقالات تخصصی ایران

- ✓ امکان دانلود نسخه تمام متن مقالات انگلیسی
- ✓ امکان دانلود نسخه ترجمه شده مقالات
- ✓ پذیرش سفارش ترجمه تخصصی
- ✓ امکان جستجو در آرشیو جامعی از صدها موضوع و هزاران مقاله
- ✓ امکان دانلود رایگان ۲ صفحه اول هر مقاله
- ✓ امکان پرداخت اینترنتی با کلیه کارت های عضو شتاب
- ✓ دانلود فوری مقاله پس از پرداخت آنلاین
- ✓ پشتیبانی کامل خرید با بهره مندی از سیستم هوشمند رهگیری سفارشات