



Effect of placement of droop based generators in distribution network on small signal stability margin and network loss



D.K. Dheer^a, S. Doolla^{a,*}, S. Bandyopadhyay^a, Josep M. Guerrero^{a,b}

^a Department of Energy Science and Engineering, Indian Institute of Technology Bombay, Powai, Mumbai 400076, India

^b Department of Energy Technology, Power Electronic Systems, Aalborg University, 9220 Aalborg, Denmark

ARTICLE INFO

Article history:

Received 27 April 2016

Received in revised form 3 November 2016

Accepted 22 December 2016

Keywords:

Islanded microgrid

Droop control

Small signal stability margin

ABSTRACT

For a utility-connected system, issues related to small signal stability with Distributed Generators (DGs) are insignificant due to the presence of a very strong grid. Optimally placed sources in utility connected microgrid system may not be optimal/stable in islanded condition. Among others issues, small signal stability margin is on the fore. The present research studied the effect of location of droop-controlled DGs on small signal stability margin and network loss on a modified IEEE 13 bus system, an IEEE 33-bus distribution system and a practical 22-bus radial distribution network. A complete dynamic model of an islanded microgrid was developed. From stability analysis, the study reports that both location of DGs and choice of droop coefficient have a significant effect on small signal stability, transient response of the system and network losses. The trade-off associated with the network loss and stability margin is further investigated by identifying the Pareto fronts for modified IEEE 13 bus, IEEE 33 and practical 22-bus radial distribution network with application of Reference point based Non-dominated Sorting Genetic Algorithm (R-NSGA). Results were validated by time domain simulations using MATLAB.

© 2016 Elsevier Ltd. All rights reserved.

1. Introduction

Growing environmental concerns competitive energy policies has led to the decentralization of power generation. Installations of distributed generators (DGs such as photovoltaic, wind, etc.) are expected to increase worldwide in the next decade [1]. Due to their location being close to consumers, DGs provide better power in terms of quality and reliability [2]. Controllable DGs along with controllable loads present themselves to the upstream network as microgrid. Microgrids when operating in grid-connected mode provide/draw power based on supply/demand within. In islanded mode (when not connected to the main grid), microgrids operate as an independent power system [2].

Optimal location of distributed generators (DGs) in a utility-connected system is well described in literature. The optimality in placement of a DG is decided by the owner based on the availability of primary resource, site, and climatic conditions. Thus, choosing an inappropriate location may result in losses and fall in power quality. Literature has widely addressed optimal placement of DGs in a network based on objective functions of energy/power loss minimization, cost minimization, voltage

deviation minimization, profit maximization, loadability maximization, etc. [3]. Different approaches, methods, and optimization techniques for DG siting and sizing are presented in [3–9].

DG siting and sizing is a multi-objective optimization problem classifiable into two groups. The first group focuses on economics of the system [9–17]. With respect to islanded microgrids, minimization of total annual energy losses and cost of energy for distributed generation is an area of much interest to investors [10]. One study [9] presented a multi-objective optimization problem of minimization of photovoltaic, wind generator and energy storage investment cost, expectation of energy not supplied, and line loss. Economic and environmental restrictions for a microgrid are outlined in [11]. Operation cost (local generation cost and grid energy cost) minimization is presented in [12]. An optimization problem considering operation cost and emission minimization is presented in [13]. Economic dispatch problem in a hybrid, droop-based microgrid is presented in [14].

The second group focuses on the optimal design of a microgrid based on technical parameters such as network losses, maximum loadability, voltage profile, reactive power, power quality, and droop setting. The assessment of maximum loadability for a droop-based islanded microgrid is presented in [18–20] considering reactive power requirements and various load types. A combined study on economic as well as on technical aspects is presented in [21]. A decision-making program for load procurement in

* Corresponding author.

E-mail address: suryad@iitb.ac.in (S. Doolla).

a distribution network is presented in [22] based on uncertainty parameters like electricity demand, local power investors, and electricity price. To improve the power quality of network, placement and control of unified power quality conditioner in renewable based sources has been introduced and its advantages and disadvantages are discussed in [23]. Optimal setting of droop to minimize the cost of wind generator is presented in [24]. One wind-generation study combined economics and stability issues due to uncertainty (volatility) and its effect on small signal stability [25,26]. This study of small signal stability in droop-based islanded microgrids is thus worthy in the context of potential benefits of optimal DG placement to grid managers.

A microgrid may present as much complexities as a conventional power system. When connected to a grid, these optimally placed and sized DGs (inverter-based) operate in current control mode, feeding maximum power to the network. When a grid is not available, these DGs shift to droop control mode for effective power sharing [27].

Two important aspects of an islanded microgrid load sharing and stability are widely addressed in literature. A higher droop in these DGs is desired for better power sharing and transient response [28–30]. Higher droop and stability margin improves the transient response of the system and hence power sharing among the sources [30]. Inappropriate settings of droop value may cause a power controller to operate at low frequency mode and fall into an unstable region [31,32]. Stability of islanded microgrids is a growing operational challenge. Based on the detailed literature survey it is found that: (1) Effect of placement of sources on stability margin in a droop based islanded microgrid and (2) Optimally placed sources based on network loss minimization in a grid connected system suffers stability problem when it gets islanded is not investigated so far. A grid-connected system optimized for DG sizing and siting may be vulnerable to small signal stability when islanded. This problem is more serious in rural areas of developing countries (e.g. India, sub-saharan Africa, etc.) where load shedding is still a common problem. As these islanded microgrids needs to operate without grid for a long time, stability is main concern. The impact of optimal DG placement on enhancement of small signal stability margin and loss minimization is investigated on a modified IEEE 13-bus low voltage distribution system, a standard IEEE 33-bus distribution system and a practical 22-bus radial distribution network of a local utility.

The paper is organized as follows: Section 2 presents a description of the system considered and the mathematical model designed for stability studies. Eigen value analysis and identified Pareto fronts are presented in Section 3. Validation of Eigen value analysis by time domain simulation is presented in Section 4, followed by conclusions of the study in Section 5.

2. System description and mathematical modeling

Microgrids integrated with renewable energy sources through voltage source inverters (VSIs), together with loads and interconnecting lines, were considered for the present study. A modified IEEE 13-bus system [33] (Fig. 1), IEEE 33-bus radial distribution system [34] (Fig. 2) and a 22-bus practical radial distribution network of Andhra Pradesh Eastern Power Distribution Company Limited (APEPDCL)[35], India (Fig. 3) were considered.

2.1. System state space equation

The modeling of VSIs, line, and load in d - q axis reference frame for small signal stability is defined in [33,36]. VSI model is divided into four sub-modules: power controller with droop control, voltage controller, current controller and LC-filter with coupling

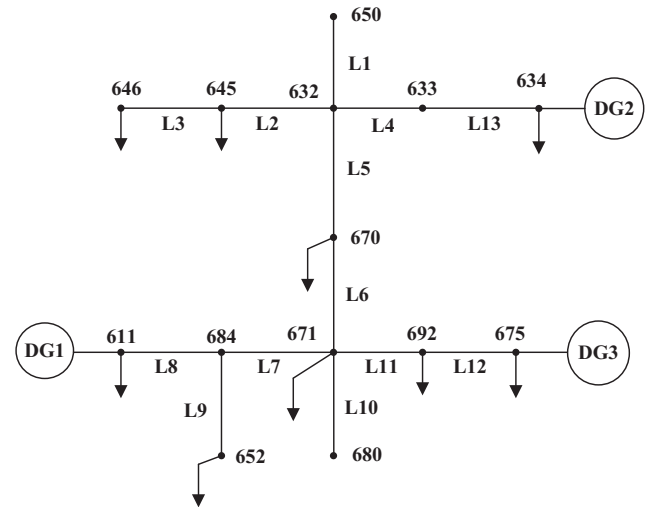

Fig. 1. Modified IEEE 13-bus system.

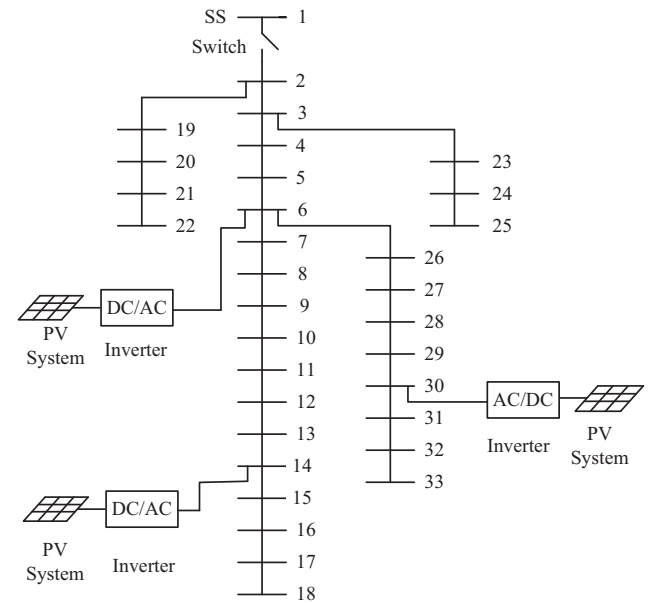

Fig. 2. IEEE 33-bus radial distribution system.

inductor. All the sources are operating in conventional droop (P-f and Q-V) to share the power as per their rating:

$$\omega = \omega_n - m_p P \quad (1)$$

$$V = V_n - n_q Q \quad (2)$$

where ω_n, V_n are nominal frequency and voltage, P and Q are filtered real and reactive power and m_p and n_q are active and reactive power droop coefficients respectively. Eq. (3) is the overall state space (matrix) equation for the total system under consideration. For the IEEE 33-bus system, the size of matrix A_{MG} with two generators is 152×152 , which includes 26 states of DGs, 62 states of lines, and 64 states of loads. With three generators, the size of A_{MG} is 165×165 (39 states of DGs, 62 states of lines, and 64 states of loads). Similarly, for the 22-bus practical radial distribution network of APEPDCL, the size of A_{MG} with three generators is 121×121 (39 states of DGs, 40 states of lines, and 42 states of loads).

متن کامل مقاله

دریافت فوری ←

ISIArticles

مرجع مقالات تخصصی ایران

- ✓ امکان دانلود نسخه تمام متن مقالات انگلیسی
- ✓ امکان دانلود نسخه ترجمه شده مقالات
- ✓ پذیرش سفارش ترجمه تخصصی
- ✓ امکان جستجو در آرشیو جامعی از صدها موضوع و هزاران مقاله
- ✓ امکان دانلود رایگان ۲ صفحه اول هر مقاله
- ✓ امکان پرداخت اینترنتی با کلیه کارت های عضو شتاب
- ✓ دانلود فوری مقاله پس از پرداخت آنلاین
- ✓ پشتیبانی کامل خرید با بهره مندی از سیستم هوشمند رهگیری سفارشات