



# Wavelet analysis of a memristor emulated model proposed for compact fluorescent lamp operated systems

Y. Babacan<sup>a</sup>, C.P. Uzunoğlu<sup>b,\*</sup>, S. Cekli<sup>c</sup>, F. Kaçar<sup>b</sup>, M. Uğur<sup>b</sup>

<sup>a</sup> Electrical and Electronics Engineering Department, Erzincan University, Erzincan, Turkey

<sup>b</sup> Electrical and Electronics Engineering Department, Istanbul University, Istanbul, Turkey

<sup>c</sup> Computer Engineering Department, Maltepe University, Istanbul, Turkey



## ARTICLE INFO

### Article history:

Received 6 June 2017

Received in revised form

17 December 2017

Accepted 3 February 2018

### Keywords:

Memristor

Compact fluorescence lamp

Wavelet analysis

Total harmonic distortion

## ABSTRACT

Compact fluorescent lamps (CFLs) are widely employed in lighting systems thanks to their energy efficient characteristics. In contrast to incandescent lamps, CFLs have highly non-linear current–voltage characteristics and exhibit harmonic distortions during their operation. Although nonlinearity and accelerated harmonic effects may cause disturbance in power networks, CFLs are frequently preferred due to their low energy consumption. In this study a test set-up is operated for investigating non-linear characteristics of commercially available CFLs. During these tests non-linear current and voltage waveforms of CFLs are analyzed via oscilloscope and compared with the proposed memristor emulator circuit output waveforms. The non-linear characteristics of CFLs are accurately modelled by proposed memristor emulator circuit, which has a tunable threshold property. To obtain proper comparison wavelet analysis is conducted for current waveforms of CFLs and memristor emulator circuit. The wavelet analysis is an efficient tool for processing non-linear signals, which are prone to display high frequency distortions. In addition to wavelet analysis, the Fourier Transform (FFT) characteristics and total harmonic distortion (THD) levels are also analyzed for correlation of CFLs and proposed memristor.

© 2018 Elsevier B.V. All rights reserved.

## 1. Introduction

In recent applications, the energy efficiency of electrical networks has become main interest since better utilization of these systems satisfy reduced consumer costs, improved signal quality and reduced environmental effects. Compact Fluorescent Lamps (CFLs) have recently been introduced to market due to their much more efficient characteristics in comparison with conventional incandescent bulbs [1–3].

CFLs can reduce electricity consumption up to seventy-five percent (in watts) compared to conventional incandescent bulbs, however increased efficiency comes with some drawbacks. CFL requires electronic ballast to initiate the operation, which naturally produces disturbing harmonic currents [4]. Increased harmonic currents causes reduced system signal quality and distorted voltage–current waveforms [5]. Increased total harmonic distortions (THD) may initiate chaotic state of the power system, which is quite common memristive systems [6].

Chua announced memristor, which was introduced as fourth passive circuit element in 1971 and 1976 [7,8]. Recently after the first announcement of memristor Strukov et al. have experimentally fabricated memristor [9]. As a fourth basic circuit element, memristor (resistor with memory), is presented as fundamental circuit component which defines charge and flux interactions contrary to other passive components.

Memristors exhibit pinched hysteresis loop when a periodic sinusoidal signal applied, and display linear characteristics at higher frequencies. The memristor resistance (memristance) depends on the input signal polarity and consequently memristance increases or decreases with the reversed polarity of the system. In order to emphasize importance of memristive systems, some useful properties of memristor such as passive circuit component structure with two terminals, hysteresis loop in the I–V (current–voltage) plot and nonlinear  $q-\varphi$  curve, apparent at small scales and no storage of energy are presented.

Many researchers have analyzed memristor and memristor based circuit system designs after its physical fabrication. SPICE models [10–13] and emulators [14–20] are developed to emulate memristors to employ with other circuit components. Memristors are suitable to design and simulate chaotic circuits because of their nonlinear behavior. For this purpose, there are various studies on

\* Corresponding author.

E-mail address: [polat@istanbul.edu.tr](mailto:polat@istanbul.edu.tr) (C.P. Uzunoğlu).

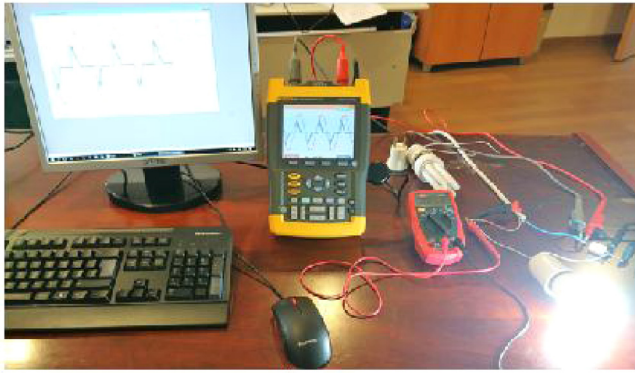

a)

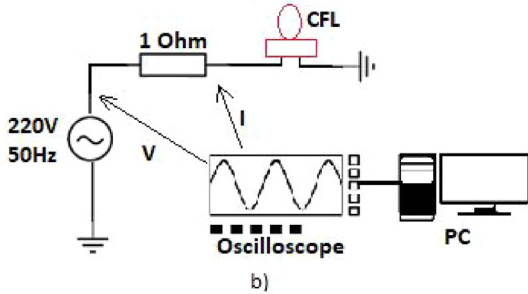

b)

Fig. 1. CFL test setup (a) experimental setup (b) block diagram.

the chaotic behavior of memristor and its circuit applications have been conducted [21–24].

In this study, proposed memristor model is investigated and compared with employed CFLs in terms of non-linear operation. The I–V characteristics of CFLs were experimentally recorded and analyzed. THD level and FFT plots were compared. The proposed memristor emulator circuit’s I–V characteristics, THD level and FFT plot were investigated and CFL simulation with proposed system is verified. In order to express the performance of the proposed memristor model, wavelet analysis is proposed for investigating nonlinear characteristics.

It is quite a challenging task to analyze non-linear signals by using conventional methods such as FFT method since this method naturally analyzes total signal frequency components instead of focusing on small fragments of the signal. In this study due to nonlinear and harmonic distortions of memristor and CFL signals, continuous wavelet transform (CWT) technique [25] is proposed for determination of non-linearity (chaoticness) of these signals. In literature, wavelet analysis has different application fields such as biomedical, mechanics, telecommunications, radar, compressing etc. [25–29].

## 2. Test setup

In order to investigate CFL characteristics the test setup, which is given in Fig. 1, is employed. As a power supply, single-phase rated 220 V–50 Hz electrical distribution network is used. Current and voltage waveforms were recorded by high speed oscilloscope. Current recordings were collected through a 1 Ω resistor (voltage signal represents current signal for a 1 Ω resistor) to observe current signal on oscilloscope. Voltage readings were obtained from phase voltage of the system.

In this study 18 W (stick bulb shape) and 23 W (spiral bulb shape) CFLs are employed and named as CFL1 and CFL2 respectively for ethical issues. Commercially available CFL1 and CFL2 lamps are investigated and corresponding signal waveforms are recorded. Signal recordings are transferred to computer for processing.

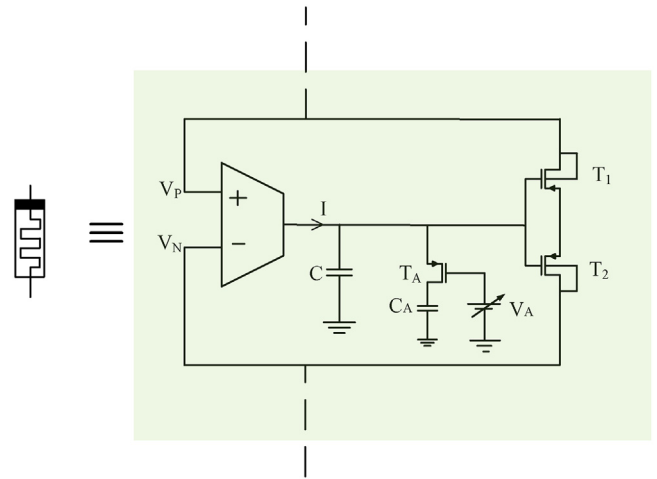

Fig. 2. Memristor circuit with tunable threshold.

## 3. Memristor emulator circuit and experimental CFL results

Strukov et al. from Hewlett Packard presented a simple mathematical memristor model [9]. Current–voltage relationship can be expressed by,

$$V(t) = R(t) i(t) = \frac{d\varphi}{dq} i(t) \tag{1}$$

Here,  $q$  and  $\varphi$  denote the charge and flux, respectively. Memristance is the ratio of flux to charge and the memristance can be changed by applying voltage or current signal across the memristor. The current–voltage relationship is,

$$V(t) = \left[ R_{ON} \frac{x(t)}{D} + R_{OFF} \left( 1 - \frac{x(t)}{D} \right) \right] i(t) \tag{2}$$

$R_{ON}$  and  $R_{OFF}$  values are low and high resistance, respectively,  $D$  denotes the thickness of memristor,  $x$  denotes the thickness of doped area in the memristor and  $\mu_V$  is the electron mobility. The variation of  $x$  value plays important role for memristor characteristics which is defined by [9],

$$\frac{dx(t)}{dt} = \mu_V \frac{R_{ON}}{D} i(t) \tag{3}$$

Current-mode structures are useful tools for circuit designers to obtain low power consumptions. For this purpose, the current mode based memristor emulator circuit is proposed as shown in Fig. 2. This circuit consists of only one voltage controlled current source element (operational transconductance amplifier-OTA), two capacitors, three MOSs and one voltage source. Gates of the MOSs are driven by the capacitor voltage. The capacitors are charged and discharged by OTA. The relationship of input voltage and output current of OTA is given by,

$$I = g_m (V_P - V_N) \tag{4}$$

Here,  $g_m$  is transconductance of OTA circuit element and output current can be controlled for both input voltages and  $g_m$  value. The threshold of memristor can be changed by using  $V_A$  voltage source.

The  $V_A$  voltage source is directly connected to the gate of TA transistor and memristor threshold voltage can be controlled by changing the  $V_A$  voltage source. The current–voltage curves with various threshold barriers are shown in Fig. 3. Besides the behavior of memristor can be controlled by changing the values of  $g_m$ , capacitors and dimensions of transistors. For instance, the memristance (the resistance of memristor) can be increased or decreased when the dimensions of transistor is decreased or increased, respectively. The operation frequency of memristor can be controlled by

متن کامل مقاله

دریافت فوری ←

**ISI**Articles

مرجع مقالات تخصصی ایران

- ✓ امکان دانلود نسخه تمام متن مقالات انگلیسی
- ✓ امکان دانلود نسخه ترجمه شده مقالات
- ✓ پذیرش سفارش ترجمه تخصصی
- ✓ امکان جستجو در آرشیو جامعی از صدها موضوع و هزاران مقاله
- ✓ امکان دانلود رایگان ۲ صفحه اول هر مقاله
- ✓ امکان پرداخت اینترنتی با کلیه کارت های عضو شتاب
- ✓ دانلود فوری مقاله پس از پرداخت آنلاین
- ✓ پشتیبانی کامل خرید با بهره مندی از سیستم هوشمند رهگیری سفارشات