

Dynamic allocation of industrial utilities as an optimal stochastic tracking problem



Pablo S. Rivadeneira^{a,b,*}, John A. Gómez Múnera^a, Vicente Costanza^a

^a Instituto de Desarrollo Tecnológico para la Industria Química, (INTEC, UNL-CONICET) Güemes 3450, 3000 Santa Fe, Argentina

^b Universidad Nacional de Colombia, Sede Medellín, Facultad de Minas, Grupo GITA - Cra. 80-223, Medellín, Colombia

ARTICLE INFO

Keywords:

Utility allocation problems
Optimal control
Tracking separation principle
Supervisory control

ABSTRACT

A new dynamic optimization strategy is substantiated for allocating demands, in a typical process plant, to a set of service equipment working in parallel. It is a stochastic process in nature, but its optimal control is based on the solution to a related deterministic optimal tracking problem to minimize a quadratic cost objective restricted by linear dynamics. The main theoretical novelty, demonstrated here, is the separation theorem for the stochastic tracking problem. This means: the desired optimal stochastic solution can be calculated from the solution to the deterministic problem, by replacing the state variable with their optimal estimates, which can be generated online following a Kalman filter scheme. The set-points assigned to each conventional controlled device are allowed to be continuously changed while: (i) minimizing a combined cost, which is cumulative in time and takes into account the dynamics of all the individual utilities, and (ii) generating a feedback law that can cope with general disturbances, like changes in fuel composition and with noisy measurements, i.e. with differences between the predicted and the measured values of the variables.

1. Introduction

Optimal allocation problems have a long tradition in engineering practice. In chemical processes, dynamic optimization frequently deals with distributing global service demands of the plant into individual targets assigned to each member of a group of service equipment, while minimizing a predetermined generalized cost. Typical service equipment (or utilities) include sets of boilers/steam generators, heat-exchangers, pumps, air-compressors, and the like (Bujak, 2009; Collins and Lang, 1998; Muller and Craig, 2014; Teles et al., 2008; Zhang et al., 2013). In what follows, the individual components from the ‘group’ under consideration will be referred to as ‘units’. Units operate in parallel to meet the total demand required to the group. Usually the individual demands translate into set-points communicated to controllers of the PID type, which are properly tuned and perform efficiently. The sum of the demands assigned to the units is always assumed to equal the total demand required from the group.

With environmental policies, rising energy costs, and a struggling global economy, there has been an increasing concern on efficiency improvement in the process industries. Energy is supplied to (or removed from) a plant mostly through utilities and a reduction in the consumption of these utilities results in a direct energy saving (Pillaia and Bandyopadhyay, 2007; Shide et al., 2009). In Fig Fig 1. a schematic

diagram of a utility group is shown (Hwan and Han, 2001). They provide vapor to the rest of the plant, where in this case power energy is generated by means of a system of turbines in parallel. The power demand is decided by a supervisory controller (depicted in green), which in turn imposes a total vapor demand to the steam generators. In traditional engineering practice this total vapor demand enters to the boiler system as a global set point (constant under normal operation conditions). The global demand α needs to be distributed into the units, realized conventionally as a constant fraction of α . A novel scheme is introduced at this point (illustrated in blue), where the set points (u_1, u_2, \dots, u_n) of each boiler are permitted to change in time, following a trajectory and decided by the Optimal Allocation Controller. In this paper two aspects of this routine will be discussed: (i) the methodology for deciding the individual set-points after a new total demand is required from a group, and (ii) the convenience of changing these orders continuously in time, by optimizing some combined cumulative cost during a fixed finite time-horizon.

This type of approach (although resorting just to time-constant set-point orders) has been applied to steam generation (Bujak, 2009; Havlena, 2009; Likins and LaSpisa, 1986) towards minimizing energy losses to the environment, or equivalently to maximize the efficiency of a set of units, defined from theoretical relations among the many physical variables involved. This approach gives rise to a static

* Corresponding author at: Instituto de Desarrollo Tecnológico para la Industria Química, (INTEC, UNL-CONICET) Güemes 3450, 3000 Santa Fe, Argentina.
E-mail address: psrivade@santafe-conicet.gov.ar (P.S. Rivadeneira).

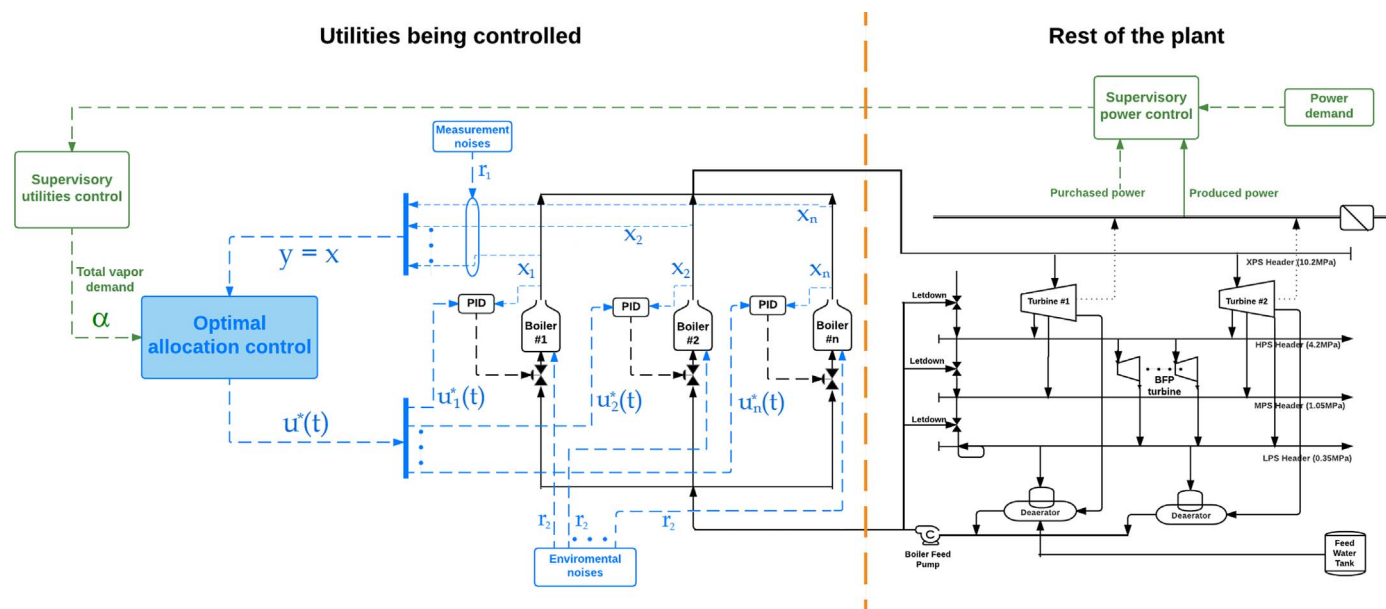

Fig. 1. Schematic diagram of supervisory control with optimal demand allocation of a utility plant. (For interpretation of the references to color in this figure, the reader is referred to the web version of this article.)

optimization problem managed by linear or nonlinear programming, exceptionally by Dynamic Programming (Hwan and Han, 2001; Mavromatis and Kokossis, 1998; Pillaia and Bandyopadhyay, 2007).

They follow static optimization lines, common to research operation engineering (see for instance Hatzopoulos et al., 2011; Xu and Zeng, 2011). To the authors' knowledge, a dynamic point-of-view has only been applied to specialized derived situations, like redundant control and related problems (Härkegård and Glad, 2005).

An original 'dynamic feedback' strategy will be sought here, in the sense that the set-points to each unit will be allowed to change continuously while: (i) minimizing a combined cost, which is cumulative in time and takes into account the dynamics of all the individual units, and (ii) generating a stochastically optimal control that copes with general disturbances, like changes in fuel composition, noisy measurements, environmental interactions and the like.

With these objectives in mind, the dynamics for the responses of each unit to set-point indications will be assessed, directly from experimental data. Then the whole group of n units will be assembled into a general model with an $(n - 1)$ -dimensional control vector associated with the first $n - 1$ set-points, the remaining one determined by the residue with respect to the global demand, which is constant during each optimization time-horizon. This new 'big' system, together with a typical quadratic cost functional conform an optimal control problem that has a close mathematical solution, leading to a linear feedback law with time-variant coefficients. Both the proportional coefficient and the feed-through term in the control law need to be calculated only once for a unitary global demand, and stored in memory, the updating procedure for another demand being straightforward. The nature of the modeling also admits a stochastically optimal handling of disturbances and systemic perturbations, and eventually a suboptimal online correction (Costanza, 2005; Costanza and Rivadeneira, 2014) of the feedback law due to hard restrictions on control values (Bujak, 2009; Havlena, 2009).

The rest of the article will be organized as follows: in Section 2 the modeling for the dynamics and the design of the cost objective are made explicit, and the optimal solution analytically found. Also the stochastic problem of estimation is posed for groups of units, and the 'Separation Principle' for tracking problems is demonstrated, which guarantees the optimality of the tandem filter-regulator. Section 3 is devoted to numerical calculations and validations, the stochastic aspects are substantiated, and all issues illustrated for boilers in a

steam utility group. The last Section exposes the conclusions.

2. Theoretical setup

2.1. State space models for utility units

In what follows it will be assumed that a group of service equipment is in operation as part of an industrial plant, its units working in parallel, evolving within the admissible range of their main variables, and that each member is efficiently controlled, according to conventional engineering practice, to meet its assigned demand.

It is commonly accepted that the dynamics of each unit is in general nonlinear (Bujak, 2009; Havlena, 2009), of the form

$$\dot{x} = f(x, v), \quad (1)$$

where x denotes the relevant states and v some manipulated variable (for instance, the water inflow). As soon as a new set-point u for the 'production' state x_1 is received, then the manipulated variable will be assumed to follow some finely tuned control strategy

$$v = k(t, u), \quad (2)$$

which 'efficiently' drives x_1 towards u in due time. Eq. (2) represents the final form that the control trajectory (generated by a controller, typically a PID) will adopt after a set-point of magnitude u is assigned. This paper will not deal with the validity of the subjacent efficiency criterion nor with the design/tuning of the control strategies $k(t, u)$.

The 'production' state x_1 is attached to the 'service' required from the equipment. For instance, if the unit were a boiler, then the value $x_1(t)$ would reflect the amount of vapor produced by the boiler at time t . It follows that there will also be at least a main 'expense' variable x_2 , necessary for the unit to actually realize the service. Again for a boiler, $x_2(t)$ could typically describe the amount of fuel that the unit is consuming at time t .

As a consequence of applying such efficient control strategies k , it can also be reasonably assumed that the dynamics of the variables x_1, x_2, u result approximately linear, i.e. that the finally controlled unit would perform well under proportionally different admissible set-points. This hypothesis has been corroborated by experimental data (Bujak, 2009; Costanza and Rivadeneira, 2015; Xu and Zeng, 2011; Havlena, 2009), and it amounts to propose a linear model for the new system, namely

متن کامل مقاله

دریافت فوری ←

ISIArticles

مرجع مقالات تخصصی ایران

- ✓ امکان دانلود نسخه تمام متن مقالات انگلیسی
- ✓ امکان دانلود نسخه ترجمه شده مقالات
- ✓ پذیرش سفارش ترجمه تخصصی
- ✓ امکان جستجو در آرشیو جامعی از صدها موضوع و هزاران مقاله
- ✓ امکان دانلود رایگان ۲ صفحه اول هر مقاله
- ✓ امکان پرداخت اینترنتی با کلیه کارت های عضو شتاب
- ✓ دانلود فوری مقاله پس از پرداخت آنلاین
- ✓ پشتیبانی کامل خرید با بهره مندی از سیستم هوشمند رهگیری سفارشات