

Investigation on X-ray irradiation on nanoscale nitride based charge trapping flash memory devices



Meng Chuan Lee^a, Hin Yong Wong^{b,*}

^a Faculty of Engineering, Multimedia University, Persiaran Multimedia, 63100 Cyberjaya, Selangor, Malaysia

^b Faculty of Engineering, Multimedia University, Persiaran Multimedia, 63100 Cyberjaya, Selangor, Malaysia

ARTICLE INFO

Keywords:

Charge trapping
Flash memory
X-ray irradiation
Charge loss
X-ray fluorescence

ABSTRACT

Charge trapping flash memory devices are susceptible to charge loss mechanisms induced by high energy irradiation such as thermal neutrons, X-rays, and gamma ray. The loss of trapped charges due to charge loss mechanism has resulted in the degradation in data retention performance and unwanted read failures in field applications. In this work, charge loss mechanisms of nanoscale nitride based charge trapping flash memory devices due to irradiation of high energy X-rays were carefully studied and examined. Nitride based charge trapping flash memory device stored charges in the nitride storage layer of an Oxide-Nitride-Oxide stack. Threshold voltage of the nitride based charge trapping flash memory cells were collected before and after X-ray irradiation done onto the memory devices. Threshold voltage distributions have shown that significant number of cells at the lower end of the program distribution had perturbed from the overall distribution that was caused by X-ray irradiation induced charge loss mechanism. In this study, the effect of the use of 300 μm Zn filter and its proximity to the device under study to mitigate the X-ray irradiation induced charge loss was also thoroughly elucidated. The results have demonstrated that 300 μm Zn filter has significantly improved the immunity of nitride based charge trap flash memory device up to 6.446 times. However, the proximity of the Zn filter to the flash memory device exacerbated up to 7.4280 times due to the impact of secondary effect in X-ray fluorescence to the device under study. Hence, this investigation concluded that X-ray irradiation is a genuine reliability concern for nanoscale nitride based charge trapping flash memory devices. Furthermore, it is recommended to place Zn filter close to X-ray source to significantly mitigate the V_t distribution drift induced by X-ray irradiation.

1. Introduction

Charge trapping flash (CTF) memory device is one of the key innovations that enabled the trend of embedded electronics which is instrumental to today's Internet of Things (IoT) trend [1–3]. As shown in Fig. 1, based on the distinct characteristics of its storage media to retain digital data, flash memory devices can be generally categorized to charge trapping and non-charge trapping based non-volatile memory (NVM) devices. Non-charge trapping based NVM devices stem from the innovation of utilizing the electrical, thermal or magnetic properties of exploratory materials as the emerging digital information storage media. Most of these non-charge trapping based NVM devices are still heavily researched due to several critical technology issues and reliability challenges. The only exception for these non-charge trapping based NVM devices is Phase Change Memory (PCM) that is currently in production. Generally, there are 5 main variants of non-charge trapping based NVM devices, i.e. Ferroelectric Random Access Memory (FeRAM), PCM, Magneto-resistive Random Access Memory (MRAM),

Resistive Random Access Memory (RRAM) and Carbon Nanotube (CNT) based NVM based on the innovation achieved on the data retention attributed to the non-charge storage media [1–3]. As compared to the rest of the non-charge trapping based NVM devices, PCM is the most mature among all and it is one of the earliest non-charge trapping based NVM devices that reached high volume manufacturing breakthrough. PCM primarily depends on the unique behavior of chalcogenide material that switches to amorphous or crystalline phases. This can be done by implementing quick electrical pulse (with distinct amplitude and timing) to generate sufficient heat that modulates between amorphous (high resistance) and crystalline (low resistance) phases in a typical PCM memory array [1–3]. On the other hand, FeRAM make use of the distinct polarization switching behavior of perovskite material to store information. MRAM utilizes the modulation in the resistance in magnetic tunnel junction (MTJ) to achieve data retention of memory devices [1–3]. For RRAM, various resistance states of the implemented transition metal oxides were utilized as data retention media through the application of different voltage levels across its structure. Last but

* Corresponding author.

E-mail address: hywong@mmu.edu.my (H.Y. Wong).

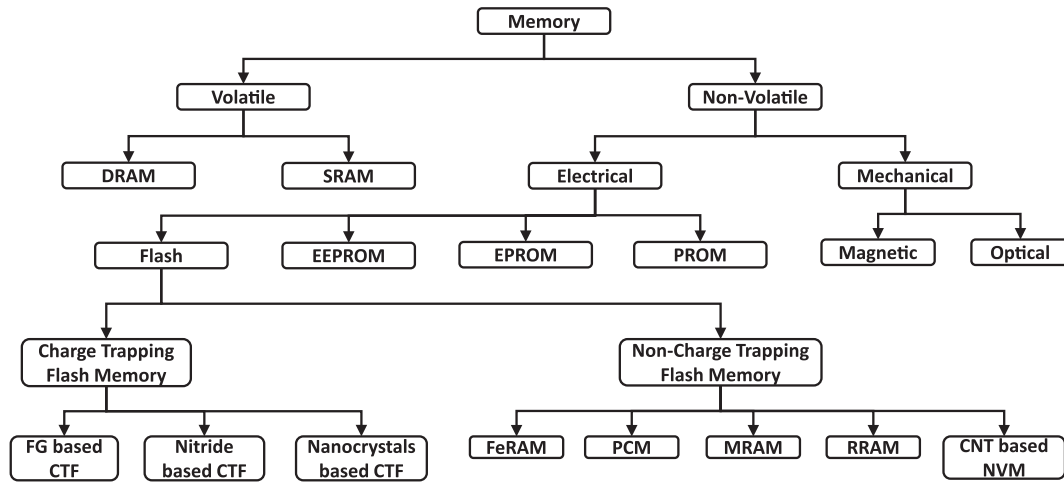

Fig. 1. The hierarchy and categorization of semiconductor memory devices.

not least, CNT based NVM utilizes the electrical and mechanical behavior of single-wall CNT that enable the storage of information through the distinct low and high conductance states [1–3].

As shown in Fig. 2, for CTF memory devices, there are 3 categories of the CTF memory devices, i.e. nitride based CTF (NB-CTF), floating gate (FG) based CTF and nanocrystals based CTF [2–3]. As shown in Fig. 2(a), FG based CTF memory device utilizes the conductive polysilicon sandwiched between silicon oxide layers as the primary charge trapping layer. Since the charge trapping layer for FG based CTF memory is conductive, the charges injected into the charge trapping

layer are stored in continuous state which bears the risk of the stored charges draining out through single point defect that existed in the silicon oxide layers [2–3]. This is especially true for FG based CTF memory since stress induced leakage current (SILC) is its Achilles' heel. As shown in Fig. 2(b), for nitride based CTF and nanocrystals based CTF memory devices, the charge trapping media is the inherent discrete charge trap present in the silicon nitride layer and nanocrystals layer of the device [2–3]. Due to the fact that the injected charges are trapped into the discrete charge trap nodes, the reliability concern that any point defects present in silicon oxide layer to drain out the trapped

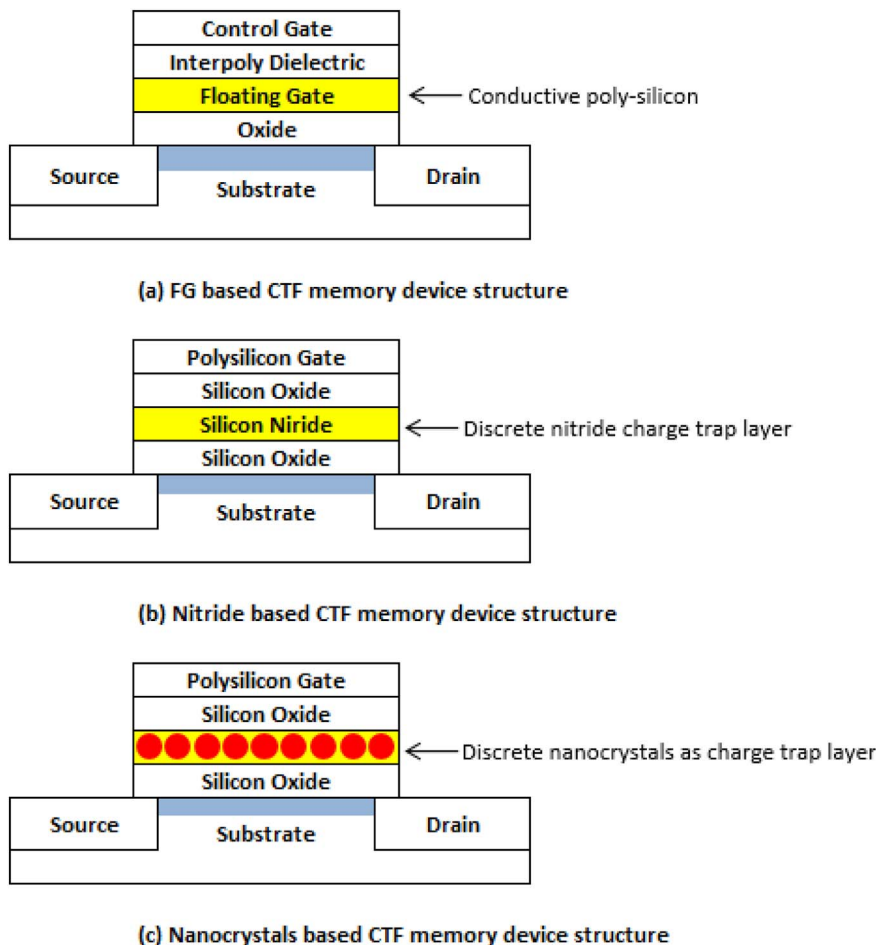

Fig. 2. Schematic diagrams of FG, nitride and nanocrystals based CTF memory device structures.

متن کامل مقاله

دریافت فوری ←

ISIArticles

مرجع مقالات تخصصی ایران

- ✓ امکان دانلود نسخه تمام متن مقالات انگلیسی
- ✓ امکان دانلود نسخه ترجمه شده مقالات
- ✓ پذیرش سفارش ترجمه تخصصی
- ✓ امکان جستجو در آرشیو جامعی از صدها موضوع و هزاران مقاله
- ✓ امکان دانلود رایگان ۲ صفحه اول هر مقاله
- ✓ امکان پرداخت اینترنتی با کلیه کارت های عضو شتاب
- ✓ دانلود فوری مقاله پس از پرداخت آنلاین
- ✓ پشتیبانی کامل خرید با بهره مندی از سیستم هوشمند رهگیری سفارشات