



Testing and design procedure for corner connections of masonry heritage buildings strengthened by metallic grouted anchors



Sara Paganoni^{a,*}, Dina D'Ayala^b

^a Department of Architecture and Civil Engineering, University of Bath, Claverton Down, Bath BA2 7AY, United Kingdom

^b Department of Civil, Environmental and Geomatic Engineering, University College London, Chadwick Building, Gower Street, London WC1E 6BT, United Kingdom

ARTICLE INFO

Article history:

Received 20 September 2013

Revised 10 March 2014

Accepted 11 March 2014

Available online 8 May 2014

Keywords:

Structural connections

Heritage buildings

Metallic anchors

Repair and strengthening

ABSTRACT

Structural connections are crucial in determining the seismic behaviour of buildings; their importance is indeed acknowledged by current design codes, both in the case of new built and of heritage structures. Eurocode 8 in particular encourages the strengthening of connections of existing structures so as to ensure global response; yet, at the state of the art, clear prescriptions regarding the assessment of connections of heritage buildings and the design of appropriate strengthening systems are missing. Even the scientific literature seldom deals with the issue of connections, both in the unreinforced and strengthened set-up. As such, designers are left with the issue of experimentally characterise the capacity of connections, and of sourcing data and choosing suitable design procedures in order to comply with the requirements prescribed for retrofit interventions on historic buildings. In the attempt of tackling the lack of quantitative data, as well as of providing template for the experimental assessment and design of strengthening systems for connections, the authors carried out two sets of laboratory tests on masonry samples strengthened by metallic grouted anchors. Parameters significant to the performance of the connection are identified through experimental results and a design procedure is developed. The paper analyses in detail the response of a widely-applied strengthening technique, but also provides general guidance for dealing with the repair and strengthening of connections of heritage buildings.

© 2014 Elsevier Ltd. All rights reserved.

1. Introduction

In the last decades, a number of technical solutions for the improvement of structural connections have been developed in response to the increasing demand for strengthening systems specifically designed for the seismic protection of heritage assets [1–7]. At the same time, the experimental assessment of strengthening techniques is a well-established practice both in the scientific community and among commercial producers.

It is therefore surprising that testing of connections as such is rarely performed, and very few codes of practice deal with this topic. Commercial strengthening techniques are generally designed and tested for the repair and upgrade of a single structural element [8,9], or at the global scale on building prototypes [10,11]. Neither methodology specifically targets the performance of unstrengthened or strengthened connections; on the other hand, the few examples of experimental procedures [3,12] devised to this purpose are not standardised or codified, and therefore hardly repeatable.

Design codes stress the importance of providing effective connections during the seismic retrofit and upgrade of heritages structures, so as to achieve a more favourable distribution of horizontal loads depending on the stiffness of structural elements [13,14]. Nevertheless, clear prescriptions for the design of strengthening systems are missing. In fact, end users are left with the difficult task of complying with code requirements with the only support of qualitative indications.

At the same time, recent post-earthquake reconnaissance campaigns [15,16] provide clear evidence of the negative impact of poorly designed and badly installed strengthening systems.

The paper aims to address the technical gaps described above by describing the testing procedures developed and adopted within the framework of the EU-funded FP7-NIKERproject (Grant Agreement No. 244123, www.niker.eu) for the assessment of masonry specimens strengthened by metallic anchors.

Cross-ties have been widely implemented over the last centuries to restore the box-like behaviour of masonry structures in many historic city centres across Europe and the Mediterranean basin. Nowadays, metallic anchors are still commonly applied as they offer the advantage of scarcely increasing the mass of the structure, while preserving its integrity and global behaviour by

* Corresponding author. Tel.: +49 17676967247.

E-mail address: S.Paganoni@bath.ac.uk (S. Paganoni).

reducing cracking phenomena. Yet, despite the improvement of installation techniques and the use of materials with better durability and performance, little research has been carried out on the performance of this strengthening system and the literature lacks design guidelines.

Therefore, two testing campaigns are carried out: the first consists of pull-out tests of grouted anchors from one element of a corner connection, namely the wall perpendicular to the seismic action. The purpose is to identify possible failure modes and the capacity of the strengthening assembly, both as a whole and as a system of components with different responses to axial loading. The second testing campaign is performed on T-shaped masonry specimens, so that the whole connection, two orthogonal walls and the strengthening element, can be studied. In this case the focus is on those factors that cannot be accounted for through pull-out tests: the effect of cyclic loading and the damage on the wall parallel to the seismic action.

Drawing on the experimental results and the technical literature, an analytical method for calculating the capacities of the various elements in the assembly is proposed and its suitability verified by comparing calculated values with those achieved experimentally. Hence, the objective of this work is not only to provide insight into the mechanics and failure modes of a widely-used strengthening technique, but also to propose a systematic and comprehensive testing and design methodology of general validity for anchorage systems in stone and brick masonry.

2. Monotonic pull-out tests

The purpose of pull-out tests is to analyse the behaviour of a connection between two vertical elements, i.e. walls, strengthened by steel anchors. The focus is on the performance of the anchor, and the damage caused to the wall perpendicular to the anchoring direction by the monotonic action of pull-out.

Given the lack of specific design clauses for anchors in masonry substrata, for the sake of homogeneity with current codes of practice, the same protocols used for pull-out test of anchors in concrete substrata [17] and of masonry bed-joint reinforcement [18] are applied. However, greater attention is given to phenomena and requirements specific to historic masonry, such as the influence of a non-homogeneous substratum on the modes of failure and the importance of damage limitation.

The technology used for anchors is the CINTEC's system© [19], which comprises a stainless steel profile encased in a fabric sleeve

that is installed in holes core-drilled in the structure and then injected by grout. The flexible sleeve of woven polyester restrains the grout flow and expands to about twice its initial diameter, moulding itself into the shape and spaces within the walls, providing mechanical as well as chemical bond. Therefore, the anchoring system relies on shear and mechanical locking for the transmission of load to the substratum; as no front plate is needed, the disruption to the architectural features is maintained to a minimum. Experimental campaigns are devised in light of the specific characteristics of the anchoring system, as explained in the following.

2.1. Test set-up

The test set-up consists of a stainless steel anchor within a grouted socket bonded to a wall subject to the pulling action of the testing apparatus, which simulates the reaction of the anchor lying within the wall being subjected to acceleration normal to its plane, tending to cause overturning (Fig. 1).

Since the test involves the presence of only one masonry panel, its application could also be implemented for the testing of anchors connecting vertical to horizontal elements (e.g. roof or floor timber rafters or joists connected to walls) when considering the performance of the anchor/wall interface.

2.2. Materials and samples

Following the prescriptions of [18] for testing of ancillary components of masonry, anchors are positioned in free-standing panels. The relative distance between anchors must be sufficient to avoid interaction effects between adjacent anchors or between anchor and wall edges. No prescription is given by design codes in this regard; the minimum distance of two diameters centre to centre that determines a group effect in the case of piles is taken instead as Ref. [20].

The positioning of the anchors in respect to bed joints, head joints and masonry units is intentionally left random, so that results can be representative of the average behaviour of anchors in an irregular substratum, although care is taken that at least one joint is included in the area of coring, so as to avoid performing a pull-out from a single brick.

A vertical load is applied throughout tests; the code [18] prescribes the use of a load apt to create a stress between 0.05 and 0.1 MPa, which simulates the typical compression stress field perpendicular to bed joints. In the tests two different values of loads

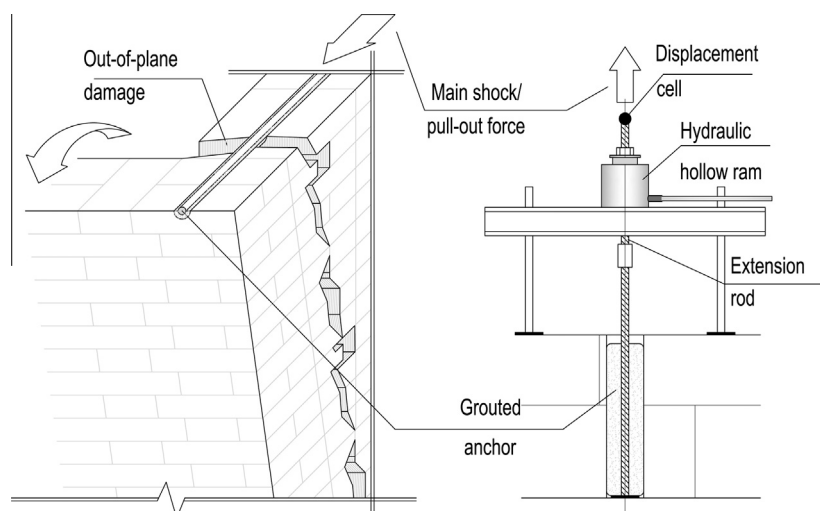

Fig. 1. Lay-out of on-site application and lay-out of experimental simulation of cross tie.

متن کامل مقاله

دریافت فوری ←

ISIArticles

مرجع مقالات تخصصی ایران

- ✓ امکان دانلود نسخه تمام متن مقالات انگلیسی
- ✓ امکان دانلود نسخه ترجمه شده مقالات
- ✓ پذیرش سفارش ترجمه تخصصی
- ✓ امکان جستجو در آرشیو جامعی از صدها موضوع و هزاران مقاله
- ✓ امکان دانلود رایگان ۲ صفحه اول هر مقاله
- ✓ امکان پرداخت اینترنتی با کلیه کارت های عضو شتاب
- ✓ دانلود فوری مقاله پس از پرداخت آنلاین
- ✓ پشتیبانی کامل خرید با بهره مندی از سیستم هوشمند رهگیری سفارشات