



Full length article

# Compensation for spatial phase aberration by use of genetic algorithm in heterodyne detection



Hongzhou Dong<sup>a,\*</sup>, Guoqiang Li<sup>b,c</sup>, Mingwu Ao<sup>a</sup>, Chunping Yang<sup>a</sup>, Yong Liu<sup>a</sup>

<sup>a</sup> State Key Laboratory of Electronic Thin Films and Integrated Devices, School of Optoelectronic Information, University of Electronic Science and Technology of China, Chengdu 610054, China

<sup>b</sup> Department of Ophthalmology and Visual Science, The Ohio State University, Columbus, OH 43212, USA

<sup>c</sup> Department of Electrical and Computer Engineering, The Ohio State University, Columbus, OH 43212, USA

## ARTICLE INFO

### Article history:

Received 5 September 2017

Received in revised form 12 January 2018

Accepted 16 February 2018

### Keywords:

Heterodyne detection

Genetic algorithm

Array detector

Sequence shifting

## ABSTRACT

The method of compensation for spatial phase aberration based on an array detector and sequence shifting has a great advantage. But in the method, the calculations of the shifting steps depend on the known optical field distributions, so the method is limited when the accurate distributions cannot be obtained. To overcome this problem, we propose to use genetic algorithm (GA) to search appropriate shifting steps, which can be performed automatically in a microcontroller unit (MCU). Because there is no need of obtaining the field distributions, the system can be simplified by omitting the two on-off controllers in the optical path. Meanwhile, the detection of a weak optical signal becomes feasible in the new method. Numerical calculations confirm that genetic algorithm can effectively determine the shifting steps and the signal-to-noise ratio (SNR) of the array detector can be increased by more than one hundred times compared with the single detector.

© 2018 Published by Elsevier Ltd.

## 1. Introduction

In optical heterodyne detection, it is well known that the spatial phase aberration of the beams severely degrades the performance of a heterodyne system [1,2]. The aberration may be caused by various factors, such as misalignment angle [3,4], turbulence [5,6], aberrations of optical components [7]. In order to decrease the effect of the aberration, some rigorous requirements must be met, such as precise alignment of the components in system, good phase wave front and excellent aberration correction of the optical components. However, these requirements are difficult to meet fully in practice. In view of the difficulty in avoiding the aberration, the study about how to compensate for it becomes a more realistic solution. As far as phase compensation concerned, to the best of our knowledge, there are two methods available. One is adaptive optical technique [8]. The fundamental is to measure firstly the wave-front distortion with Shack-Hartman wave-front sensor [9] or shearing interferometer [10], and then the distortion is compensated for by a system composed of electro-optic, acousto-optic devices and deformable mirror. The technique needs a large-scale computer control system and servo device. The system is quite expensive. The other method is based upon phase conjugate mirror

[11,12]. The mirror can generate a conjugate wave of the distorted one. Exploiting the physical phenomena of self-pumped and mutually pumped phase conjugation, one can obtain a matching wave-front distribution. However, this could only be achieved when the position and orientation of the incident beams meet certain conditions, which results in the difficulty in proper alignment of the relevant components. Even if the conditions are met, the conjugated reflectivity is still very low. Hence, further efforts are still demanded if one wants to apply this technique in practice.

To overcome the above mentioned problems, we have proposed a method based on array detector [13]. In the array, every detector element corresponds to a fragment of the spatial phase aberration. Like this, the effect of the aberration fragment is to generate a random phase in the heterodyne signal output from the element. For the heterodyne signal, there is a certain phase difference between the adjacent two samples of analog-to-digital converter (ADC). Based on this fact, if the signal sequences output from the detector elements are shifted by different steps and then they are summed as the total output, it is possible to compensate the spatial phase aberration when the shifting step depends on the quantity of spatial phase aberration. According to the method in Ref. [13], the first step is to obtain the field distributions of the signal and the local oscillation (LO) beams. Then, the aberration of each element can be calculated based on the distributions. Finally, the shifting steps of all sequences can be determined from the values of these quan-

\* Corresponding author.

E-mail address: [hzdong@uestc.edu.cn](mailto:hzdong@uestc.edu.cn) (H. Dong).

tities. We have proved numerically in Ref. [13] that the method is effective to compensate the spatial phase aberration. The method can be performed in a circuit module of the array detector, so there is no need of extra optical device to compensate the aberration, which allows ease of implementation compared with the existing methods. However, when the optical power of the signal beams is very weak which is the usual case, it is difficult to obtain the field distribution of the signal beams. As a result, the quantities of the spatial phase aberration cannot be calculated. Thereby, it is also difficult to determine the shifting steps of the sequences. In this case, the method in Ref. [13] is less effective. So, it is necessary to propose a more feasible approach to determine the shifting steps of the sampling sequences.

The nature of spatial phase compensation based on an array is to realize an equiphase superimposition of the outputs from all detector elements. In fact, the process can be seen as a coherent accumulation. The only difference is that the time-domain random phases caused by time-jitter need to be eliminated in coherence accumulation. We have successfully applied sequence shifting and genetic algorithm to do that in coherent accumulation [14,15]. In this paper, we use also genetic algorithm to determine the appropriate shifting step of each sequence output from detector element. We simulate the spatial phase aberrations by use of Zernike polynomials, which can be used for examining the effectiveness of our method. The numerical results show that genetic algorithm is effective to find out the appropriate shifting steps. Accordingly, the SNR of the array detector shows a significant improvement in comparison with that of the single detector. Furthermore, compared with the system in Ref. [13], the new system is simpler by omitting the two on-off controllers in the optical path. Meanwhile, the new method is also effective in the case when the optical power of signal beams is weak.

**2. Fundamental theory of spatial phase compensation by use of sequence shifting**

Although the fundamental of the compensation for spatial phase aberration based on array has been described in Ref. [13], we still give a new schematic diagram in Fig. 1 in order to facilitating the following elaboration. In practice, let  $f_h$  denote the heterodyne frequency and suppose that the sampling frequency of ADC is  $w$  times higher than  $f_h$ . We may get the sampling time interval  $\Delta t = 1/wf_h$ . Thus,  $t$  is rewritten as following

$$t = k\Delta t + t_0 = k/wf_h + t_0, \tag{1}$$

where  $t_0$  is initial time,  $k$  is the serial number of sampling data and  $k = 0, 1, 2, \dots$ . If a single point detector is replaced by an array

detector shown in Fig. 1, according to Eq. (10) in Ref. [13], the heterodyne signal sequence of the detector element in the  $m$ th row and the  $n$ th column can be described by

$$i_{m,n}^h(k) = \sqrt{\gamma_{m,n}^2 + \beta_{m,n}^2} \sin[\omega_h(k/cf_h + t_0) + \theta_{m,n}]. \tag{2}$$

where

$$\gamma_{m,n} = \frac{q_e \eta}{h\nu} \iint_{A_{m,n}} |E_S(x,y)| |E_L(x,y)| \cos[\Delta\phi(x,y)] dx dy, \tag{3}$$

$$\beta_{m,n} = \frac{q_e \eta}{h\nu} \iint_{A_{m,n}} |E_S(x,y)| |E_L(x,y)| \sin[\Delta\phi(x,y)] dx dy, \tag{4}$$

$$\theta_{m,n} = \arctg\left(\frac{\gamma_{m,n}}{\beta_{m,n}}\right). \tag{5}$$

where  $A_{m,n}$  is the photosensitive area of the detector element,  $\eta$  is the quantum efficiency of the detector,  $h$  is Planck constant,  $q_e$  is the electronic charge of the electron,  $\nu$  is the optical frequency.  $\omega_h$  is the angular frequency of the heterodyne signal,  $\Delta\phi(x,y)$  is the phase difference between the two beams. When  $\Delta\phi(x,y)$  is not constant, it is defined as spatial phase aberration.  $\Delta\phi(x,y)$  is just the target needed to be compensated in this paper. One can find that the phase term  $\theta_{m,n}$  is related to  $\Delta\phi(x,y)$ . If  $\theta_{m,n}$  is eliminated, the spatial phase aberration can be compensated to a certain extend. Correspondingly, the direct current of the element in the  $m$ th row and the  $n$ th column may be obtained from Eq. (10), Ref. [13] and it can be expressed by

$$i_{m,n}^{dc} = \frac{q_e \eta}{h\nu} \iint_{A_{m,n}} (|E_S(x,y)|^2 + |E_L(x,y)|^2) dx dy \tag{6}$$

where  $E_S(x,y)$  and  $E_L(x,y)$  are the field distributions of the signal and LO beams, respectively. Eq. (6) will be used in the subsequent part for calculating the noise current output from the element.

**3. Compensation for spatial phase aberration by using time-domain phase**

Let  $\Delta\psi$  be the phase difference between the two adjacent samples of ADC. We have

$$\Delta\psi = \omega_h \Delta t = 2\pi/w. \tag{7}$$

Please, note that there is phase difference  $\Delta\phi$  between  $i_{m,n}^h(k)$  and  $i_{m,n}^h(k+1)$ . So, another phase difference  $\psi = l_{m,n} \Delta\psi$  should exist between  $i_{m,n}^h(k)$  and  $i_{m,n}^h(k_{m,n})$ , where  $k_{m,n} = k + l_{m,n}$ ,  $l_{m,n}$  is an inte-

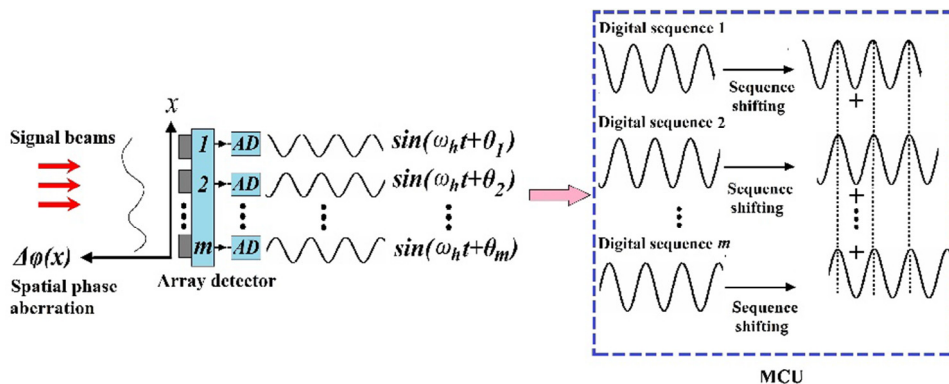

Fig. 1. Schematic diagram of the compensation for spatial phase aberration based on array.

متن کامل مقاله

دریافت فوری ←

**ISI**Articles

مرجع مقالات تخصصی ایران

- ✓ امکان دانلود نسخه تمام متن مقالات انگلیسی
- ✓ امکان دانلود نسخه ترجمه شده مقالات
- ✓ پذیرش سفارش ترجمه تخصصی
- ✓ امکان جستجو در آرشیو جامعی از صدها موضوع و هزاران مقاله
- ✓ امکان دانلود رایگان ۲ صفحه اول هر مقاله
- ✓ امکان پرداخت اینترنتی با کلیه کارت های عضو شتاب
- ✓ دانلود فوری مقاله پس از پرداخت آنلاین
- ✓ پشتیبانی کامل خرید با بهره مندی از سیستم هوشمند رهگیری سفارشات