



# Experimental investigation of hydronic air coil performance with nanofluids

Roy Strandberg, Debendra Das\*

Department of Mechanical Engineering, University of Alaska, Fairbanks, P.O. Box 755905, Fairbanks, AK 99775-5905, USA



## ARTICLE INFO

### Article history:

Received 21 November 2017

Received in revised form 25 February 2018

Accepted 26 February 2018

## ABSTRACT

The objective of this study is to experimentally characterize and compare the performance of a nanofluid comprised of  $\text{Al}_2\text{O}_3$  nanoparticles with 1% volumetric concentration in a 60% ethylene glycol/40% water (60% EG) solution to that of 60%EG in a liquid to air heat exchanger. The test bed used in the experiment was built to simulate a small air handling system typical of that used in HVAC applications. Previously established empirical correlations for thermophysical properties of fluids were used to determine the values of various parameters (e.g. Nusselt number, Reynolds number, and Prandtl number). The testing shows that the 1%  $\text{Al}_2\text{O}_3$  nanofluid generates a marginally higher rate of heat transfer than the 60% EG under certain conditions. At  $Re = 3000$ , the nanofluid produced a rate of heat transfer that was 2% higher than that of the 60% EG. The empirically determined Nusselt number associated with the convection in the coil tubing for the nanofluid follows the behavior predicted by the Dittus-Boelter correlation ( $R^2 = 0.97$ ), while the empirically determined Nusselt number for the 60% EG follows the Petukhov correlation similarly ( $R^2 = 0.97$ ). Pressure loss and hydraulic power for the nanofluid were higher than for the base fluid over the range of conditions tested. The exergy destroyed in the heat exchange and fluid flow processes were between 9% and 12% lower for the nanofluid than the base fluid over the tested range of Reynolds numbers.

© 2018 Elsevier Ltd. All rights reserved.

## 1. Introduction

Heat transfer fluids that are enhanced with extremely small particles (<100 nm in their characteristic dimension, called “nanoparticles”) in dispersion, are often referred to as “nanofluids.” These fluids have been shown in studies by multiple authors to exhibit superior thermal conductivity to that predicted by conventional correlations developed for fluids enhanced with micrometer-sized particles [1–3]. Other studies have focused on developing correlations to predict the Nusselt number of turbulent internal flows for nanofluids [4,5]. These studies suggest that Nusselt numbers for nanofluids are superior to those of the base fluid under certain flow conditions (at equal Reynolds numbers for instance), and correspondingly superior convective heat transfer coefficients in turbulent internal flows when compared to conventional heat transfer fluids. The dispersion of the nanoparticles into fluids also results in higher viscosity depending on particle mean diameter, concentration and temperature. Under certain flow conditions (for constant average liquid velocity, for instance), this can result in higher pumping losses, and reduction in Reynolds number

at a given flow rate, which can, in turn, actually decrease the Nusselt number when compared to conventional fluids. These factors must be weighed against each other in evaluating the suitability of nanofluids for use in any heat transfer application.

Liquid to air finned heat exchangers (or “coils”) are typically used to heat or cool air in building Heating Ventilating and Air Conditioning (HVAC) applications. These heating/cooling coils typically employ rows of close packed metallic (usually aluminum) fins that have been mechanically attached to thin walled copper tubes (see Fig. 1). Heat transfer fluid is passed through the copper tubing while air passes over the close packed fins, accomplishing heat transfer between the heat transfer liquid and the outside air. Liquid and airflow is in a “crossflow” pattern. Large heating coils are used in central air handling units, while smaller versions are employed in unit heaters and duct mounted coils. The application of nanofluids in heating coils may result in several potential benefits including increased heating capacity for equal liquid and airflow. These performance improvements, in turn, may be translated into a reduction in total required heat transfer area, which may be reflected in lower fin density, and thus lower air-side pressure drop and fan energy requirement. Superior heat transfer properties may also result in lower liquid flow rate for a given rate of heat transfer, yielding a reduction in liquid pumping energy for a given rate of heat transfer.

\* Corresponding author.

E-mail address: [dkdas@alaska.edu](mailto:dkdas@alaska.edu) (D. Das).

**Nomenclature**

$A$	total heat transfer area ( $\text{m}^2$ )
$B$	exergy ( $\text{J/s}$ )
$c_p$	specific heat ( $\text{J/kg K}$ )
CFM	cubic feet per minute
$d_p$	particle diameter (m)
$D$	diameter of tubing (m)
$f$	darcy friction factor
$G$	mass velocity ( $\text{kg/m}^2 \text{s}$ )
GPM	gallons per minute
$g$	gravitational acceleration ( $\text{m/s}^2$ )
$h$	convective heat transfer coefficient ( $\text{W/m}^2 \text{K}$ )
$j$	colburn J-factor
$k$	thermal conductivity ( $\text{W/m K}$ )
$L$	length (m)
LMTD	log mean temperature difference (K)
$n$	number of observations
$\dot{m}$	mass flow rate ( $\text{kg/s}$ )
$Nu$	Nusselt number ( $hD_i/k$ )
$\Delta P$	pressure drop (Pa)
$Pr$	Prandtl number ( $c_p\mu/k$ )
$\dot{Q}$	rate of heat transfer (W)
$r$	outside radius of tubing (m)
$Re$	Reynolds number ( $\rho V D_i/\mu$ )
$T$	Temperature (K)
$U$	overall heat transfer coefficient ( $\text{W/m}^2 \text{K}$ )

$\dot{V}$	volumetric flow ( $\text{m}^3/\text{s}$ )
$\dot{W}$	pumping power (W)

**Greek symbols**

$\alpha$	thermal diffusivity ( $k/\rho c_p$ )
$\varepsilon$	pipe roughness (m)
$\kappa$	Boltzmann constant ( $1.3806503 \times 10^{-23} \text{ m}^2 \text{ kg/s}^2 \text{ K}$ )
$\mu$	dynamic viscosity (Pa s)
$\eta$	fin efficiency
$\phi$	volumetric concentration
$\rho$	density ( $\text{kg/m}^3$ )

**Subscripts**

$a$	ambient
$air$	air
$i$	inside
$in$	inlet
$bf$	base fluid
$liq$	liquid
$nf$	nanofluid
$o$	outside
$out$	outlet
$s$	nanoparticle
$w$	water

Strandberg and Das [6] previously performed an analysis on the performance of hydronic heating coils with nanofluids and conventional fluids. This study indicated that coils filled with  $\text{Al}_2\text{O}_3/60:40$  EG/Water (by mass) nanofluids (heretofore referred to as 60% EG) exhibit superior heating output to those of the coils filled with 60% EG base fluid. One of the significant findings of the study was that the largest potential benefit of nanofluids in terms of pumping power reduction for a given heating output occurs under conditions where the coil operates at less than design capacity. Since typical HVAC systems spend the majority of their operating time at “off-design” conditions, nanofluids may have the potential to generate significant reductions in power consumption over the life of a typical HVAC system.

The existing literature reporting on experimental work concerning the performance of nanofluids in forced convection in the area of HVAC is quite limited. Pandey and Neva [7] reported on the performance of an  $\text{Al}_2\text{O}_3$ /water nanofluid as a coolant in a brazed plate heat exchanger, and determined that the 2% nanofluid exhibited the most superior heat transfer performance of all nanofluids tested. Vajjha et al. [4] tested three different nanofluids with 60% EG as the base fluid and developed a series of correlations for Nusselt number and friction factor under fully developed, turbulent flow conditions, and found that  $\text{Al}_2\text{O}_3$  nanofluids were superior to the others tested. Farajollahi et al. [8] performed an experimental study of water based nanofluids with  $\text{TiO}_2$  and  $\gamma\text{-Al}_2\text{O}_3$  in a test bed employing a shell and tube heat exchanger

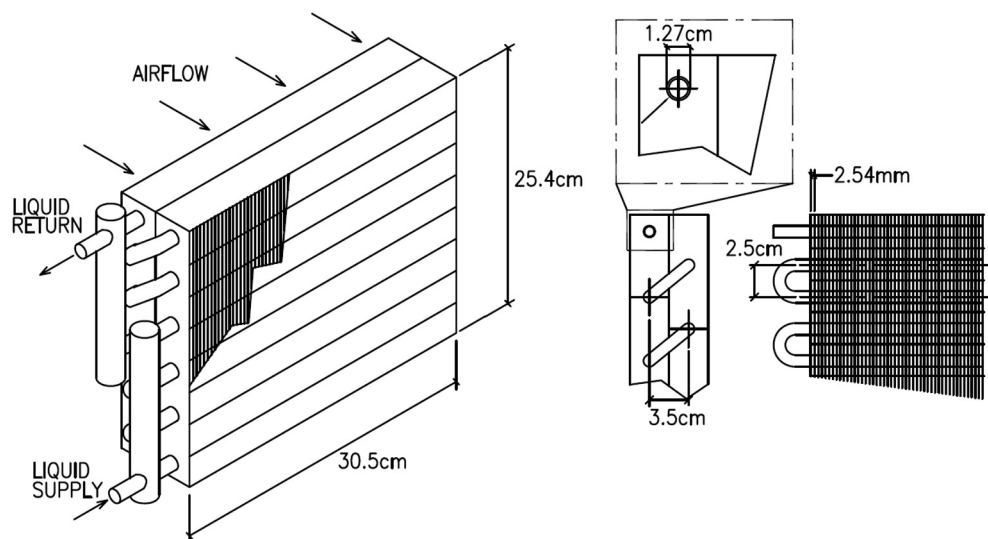

**Fig. 1.** Finned heating coil configuration.

متن کامل مقاله

دریافت فوری ←

**ISI**Articles

مرجع مقالات تخصصی ایران

- ✓ امکان دانلود نسخه تمام متن مقالات انگلیسی
- ✓ امکان دانلود نسخه ترجمه شده مقالات
- ✓ پذیرش سفارش ترجمه تخصصی
- ✓ امکان جستجو در آرشیو جامعی از صدها موضوع و هزاران مقاله
- ✓ امکان دانلود رایگان ۲ صفحه اول هر مقاله
- ✓ امکان پرداخت اینترنتی با کلیه کارت های عضو شتاب
- ✓ دانلود فوری مقاله پس از پرداخت آنلاین
- ✓ پشتیبانی کامل خرید با بهره مندی از سیستم هوشمند رهگیری سفارشات