



# An innovative solar-powered absorption refrigeration system combined with liquid desiccant dehumidification for cooling and water



Bosheng Su, Wei Han\*, Hongguang Jin

*Institute of Engineering Thermophysics, Chinese Academy of Sciences, 11 Beisihuanxi Rd., Beijing 100190, PR China*  
*University of Chinese Academy of Sciences, No. 19A Yuquan Rd., Beijing 100049, PR China*

## ARTICLE INFO

### Keywords:

Absorption refrigeration  
 Liquid desiccant dehumidification  
 Solar energy utilization  
 Fresh water production  
 Exergy analysis  
 Economic analysis

## ABSTRACT

Air-conditioning and fresh water are increasingly required in civilian and industrial sectors; however, conventional technologies are generally individual systems and consume substantial electric power. This paper proposes a new solar-powered double-product system for cooling and water based on the absorption refrigeration cycle. Integrated with liquid desiccant dehumidification, the moisture of process air can be converted into fresh water without the use of an additional desalination unit. Adopting commercially established technologies, including absorption refrigerators and liquid desiccant dehumidifiers, the system exhibits enhanced energy and economic performance. With the same system output, the energy saving ratio in the proposed system could reach 25.64%. The exergy efficiency ( $\eta_{ex}$ ) for the proposed system reaches 9.83%, which is 2.97% higher than that in the reference systems. Economic studies show the enhanced economic performance of the new poly-generation system. This study provides a new method to simultaneously produce cooling and water by efficiently using solar energy.

## 1. Introduction

Air conditioning and fresh water are essential for human survival and social development, including agricultural and industrial activities [1]. In hot and humid areas, substantial electric power is consumed by conventional vapor compression air-conditioning systems (VCSs). Relying on high-grade energy, production of chilled water with a temperature as low as 7 °C for the dehumidification of air results in a large waste of energy quality and various other problems, such as the growth of bacteria above the outer surface of the evaporator coil and global environmental challenges (e.g., depletable fossil fuel consumption and global warming) [2]. Moreover, increases of industrial and human activities and world population growth have also led to excessive need for potable/drinkable water, especially in hot and dry climatic regions [3]. However, the existing large-scale desalination plants, including multi-stage flash (MSF), multi-effect desalination (MED), reverse osmosis (RO) and electro-dialysis (ED), suffer from the problems of difficulty of maintenance, relatively high energy consumption and high cost, leading to high ecological footprints [4].

Thus, a poly-generation system, i.e., the simultaneous production of fresh water and air-conditioning, is often required in warm-climate and water-deficient regions and is often more energy-efficient than making the same products by separate single-product systems. The significant

advantages have been validated by both theoretical assessment and experimental results for an increasing number of poly-generation systems in the open literature [5]. A literature review is given to summarize the system configurations of poly-generation systems for cooling and water.

Humidification-dehumidification (HDH) desalination systems are identified as suitable for small- and medium-scale fresh water production with affordable initial and running costs in developing countries [6], and this technology can be easily integrated with a vapor compression chiller for double products. Nada et al. [3] proposed four hybrid air-conditioning and HDH desalination systems with different system configuration, in which a vapor compression chiller is adopted to cool the humidified air for air-conditioning and, at the same time, condense the water vapor in the dehumidified air for fresh water production. An experimental study was performed on a simplified hybrid air-conditioning and HDH desalination system [7]. Elattar et al. [8,9] proposed a solar-powered hybrid air-conditioning and HDH desalination system. Solar energy is used to heat the process air and the raw water for higher moisture content in the humidified air, thus resulting in higher yields of fresh water. Part of the moisture in the air is preliminarily removed in the first-stage dehumidifier and then removed further by the chilled water from the vapor compression cycle. Though hybrid air-conditioning and HDH desalination systems can realize poly-

\* Corresponding author at: Institute of Engineering Thermophysics, Chinese Academy of Sciences, 11 Beisihuanxi Rd., Beijing 100190, PR China.  
 E-mail address: [hanwei@iet.cn](mailto:hanwei@iet.cn) (W. Han).

Nomenclature		$T$	temperature, K
$C_p$	specific heat capacity, kJ/(kg K)	$y$	mass concentration, %
$COP$	coefficient of performance	<i>Greek symbols</i>	
$d$	humidity ratio, g/kg	$\eta_{ex}$	exergy efficiency
$E$	exergy, kW	$\eta_{col}$	solar collecting efficiency
$ED$	exergy destruction, kW	<i>Subscripts and superscripts</i>	
$GOR$	gained output ratio	0	restricted dead state
$GOR_{sol}$	gained output ratio of solar energy	a	air
$h$	specific enthalpy, kJ/kg	col	collector
$h_{fg}$	latent heat of vaporization of water, kJ/kg	ex	exergy
$H$	enthalpy, kW	gen	generator
$m$	mass flow rate, kg/h	heat	thermal energy
$NTU_m$	number of mass transfer units	in	input
$P$	absolute pressure, kPa	pro	proposed system
$Q$	heat transfer rate, kW	ref	reference system
$Q_{gain,s}$	the energy gained by supply air	sol	solar energy
$R$	gas constant, 8.314 kJ/kmol	w	water
$s$	specific entropy, kJ/(kg K)		
$S$	entropy, kJ/K		
$t$	temperature, °C		

generation with higher energy utilization efficiency, substantial power is still needed for the compressor. Dual-effect (cooling and desalination) adsorption-desalination systems (ADS) is an emerging and efficient thermally driven method [10], but the technical maturity still remains to be improved. However, beyond that, an absorption refrigeration system (ARS) can be suitably applied to a poly-generation system. Chiranjeevi et al. [11] proposed a new poly-generation system adopting a two-stage HDH. In the last stage of the air dehumidification, a solar-driven absorption refrigeration chiller is used to remove the moisture and realize the air-conditioning. However, large amounts of low-temperature heat in the refrigeration cycle are dissipated into the ambient atmosphere from the condenser and absorber, which clearly causes energy waste and the heat island effect.

Thus, many studies have reported utilization of the low-temperature heat of the refrigeration cycle for fresh water production. Farsi et al. [12] proposed a combined supercritical CO<sub>2</sub> refrigeration and multi-effect desalination system, in which the condensation heat drives an MED system for water production. To further improve the system performance, two-stage compression is substituted for the conventional one-stage compression in an enhanced system, and the heat of the inter-stage cooling is coupled with the MED system [13]. Hogerwaard et al. [14] proposed a method to use the inter-stage heat of the compressors in a cascade manner by successively driving a single-effect refrigeration

chiller and a flash desalination system for cooling and water. To use more renewable energy instead of conventional power to drive the heat pump, the heat pump compressor can be connected to a solar photovoltaic energy system [15]. Using condensation heat of the absorption refrigeration cycle to realize the desalination is also a potential energy-efficient technology, which has been considered much in recent years. Sahoo et al. [16] proposed a solar- and biomass-powered poly-generation system, in which the steam from an intermediate stage of the turbine is supplied to the generator of the absorption refrigeration cycle, and then its condensation heat drives an MED system. Gude et al. [1] proposed a solar-assisted absorption refrigeration system for cooling, in which the condensation heat is used to produce the fresh water in a single-effect distillation unit. Wang and Lior [17,18] combined MED and a refrigeration system based on the LiBr-H<sub>2</sub>O absorption cycle. Alelyani et al. [19] utilized the condensation heat of an ammonia-water absorption refrigeration to drive an MED system. Esfahani et al. [20,21] proposed a combined vapor-compression refrigeration and MED system. The simulation results showed that the energy and economic performances of these new hybrid systems can be enhanced by comparing with the conventional individual systems. The above-mentioned hybrid systems both use the conventional condensation dehumidification method for air-conditioning and require an additional desalination system for fresh water production.

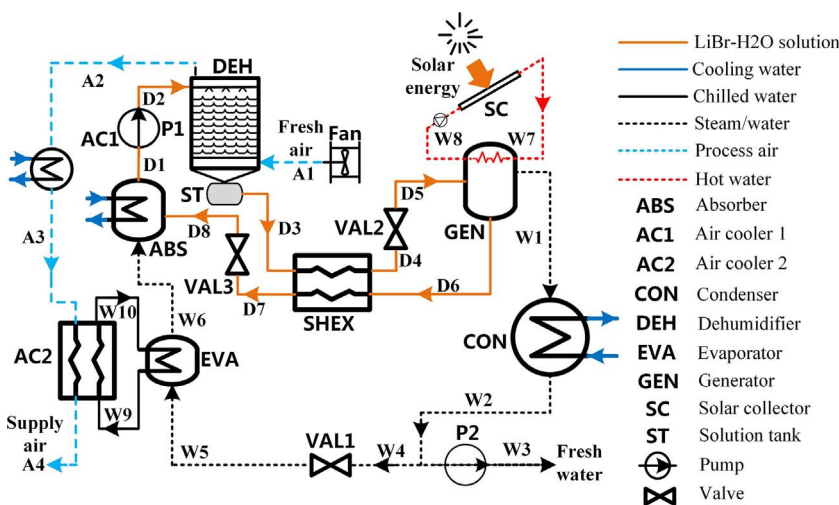

Fig. 1. Flow chart of the solar-powered absorption refrigeration system combined with liquid desiccant dehumidification.

متن کامل مقاله

دریافت فوری ←

**ISI**Articles

مرجع مقالات تخصصی ایران

- ✓ امکان دانلود نسخه تمام متن مقالات انگلیسی
- ✓ امکان دانلود نسخه ترجمه شده مقالات
- ✓ پذیرش سفارش ترجمه تخصصی
- ✓ امکان جستجو در آرشیو جامعی از صدها موضوع و هزاران مقاله
- ✓ امکان دانلود رایگان ۲ صفحه اول هر مقاله
- ✓ امکان پرداخت اینترنتی با کلیه کارت های عضو شتاب
- ✓ دانلود فوری مقاله پس از پرداخت آنلاین
- ✓ پشتیبانی کامل خرید با بهره مندی از سیستم هوشمند رهگیری سفارشات